

BOXXER H₂O

Machine Serial Number _____

Copyright© 2007
HYDRAMASTER© Corporation
Mukilteo, Washington

MAN-182-136

No part of this manual may be reproduced or used in any form or by any means (i.e. graphic, electronic, photocopying or electronic retrieval systems) without the express written permission of the **HYDRAMASTER**© Corporation. All rights reserved.

Revised September 18, 2007

Table of Contents

Table of Contents
List of Figures
Quick Reference

GENERAL INFORMATION	Section 1
Telephone Numbers	1-2
Precautions	1-3
Responsibilities	1-5
Vehicle Preparation	1-7
High Altitude Operation Preparation	1-11
Local Water Precautions	1-12
MACHINE SPECIFICATIONS	Section 2
Machine Layout	2-2
OPERATING INSTRUCTIONS	Section 3
MACHINE MAINTENANCE	Section 4
Maintenance Log	
MACHINE ASSEMBLIES AND PARTS LIST	Section 5
VACUUM SYSTEM	Section 6
Vacuum System Troubleshooting	6-2
Miscellaneous Troubleshooting	6-3
Blower Manual	
ELECTRICAL SYSTEM	Section 7
Wiring Diagrams	7-3
Electrical Troubleshooting	7-5
ENGINE TROUBLESHOOTING	Section 8
HOW TO ORDER PARTS	Section 9
WARRANTY INFORMATION	Section 10
Golden Guarantee®	

List of Figures

Fig. 1-1	Roof Vents	1-7
Fig. 1-2	Recommended Placement	1-8
Fig. 1-3	Installation Using Tie-down Cleats	1-9
Machine Assemblies and Parts Lists		5-1
Fig. 5-1	Machine Assembly - Front View - Left Side	5-1
Fig. 5-2	Machine Assembly - Front View - Right Side	5-2
Fig. 5-3	Frame Assembly - Front View - Left Side	5-3
Fig. 5-4	Frame Assembly - Front View - Right Side	5-4
Fig. 5-5	Engine Assembly	5-6
Fig. 5-6	Blower Assembly	5-8
Fig. 5-7	Dash Assembly	5-10
Fig. 5-8	Exhaust Assembly	5-12
Fig. 5-9	Machine Left Side Cover Assembly	5-14
Fig. 5-10	Machine Right Side Cover Assembly	5-15
Fig. 5-11	100 Gallon Universal Recovery Tank Assembly	5-16
Fig. 5-12	100 Gallon Universal Recovery Tank Cover Assembly	5-19
Fig. 5-13	Vacuum Relief Valve Assembly	5-20
Fig. 5-14	Dura-Flow APO Pump Assembly	5-21
Fig. 7-1	Wiring Schematic	7-3
Fig. 7-2	Wiring Diagram	7-4

Quick Reference

Fuel Pump Assembly
B-4627 Rev -

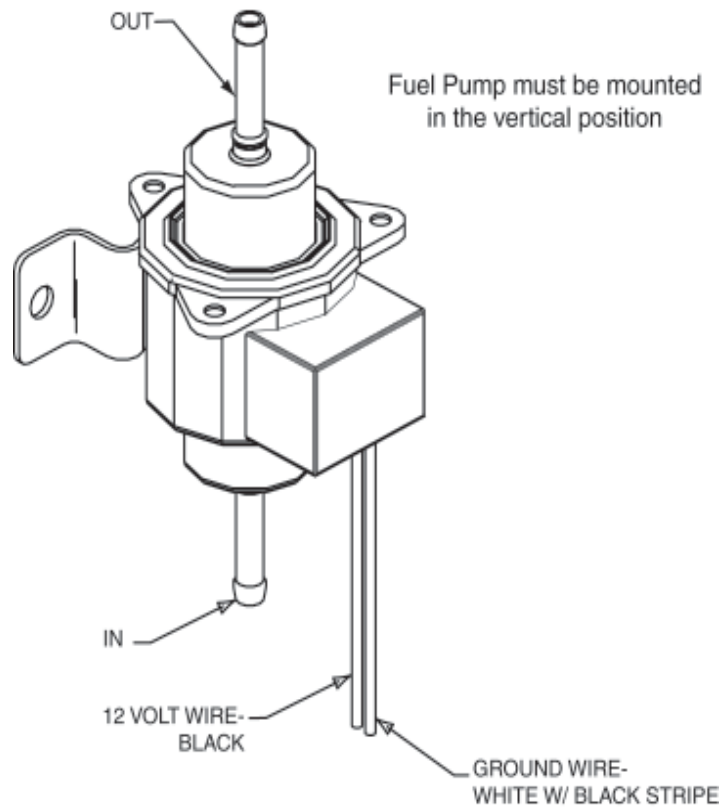

Boxxer H₂O

This page intentionally left blank.

General Information



The HydraMaster Boxxer H2O is a purpose designed machine to accommodate the needs of the Water Restoration Contractor who is extracting water and not cleaning carpet. The basis of the machine is a 27 HP Liquid Cooled V Twin engine that is directly coupled via the patented BUCS coupling system to a Tuthill 4007 Dominator blower. This combination produces over 400 CFM of air flow, more than enough to extract water with one or two wands.

In addition to this high performance Power Pack, the Boxxer H2O comes with a 100 gallon recovery tank. The reliable Dura-Flo Automatic Pump Out is an option which allows you to extract water without the need to shut down and empty the recovered water.

In addition to the obvious performance aspects of this machine, it was designed to deliver maximum reliability and to be easily serviced. All the major components have been proven in other HydraMaster Truckmounts and this new machine was put together with an eye towards simple, quick maintenance. All service points are conveniently located so routine maintenance takes only a few minutes to perform.

As with any machine, it is important to use the Boxxer H2O correctly. Operating the machine is simple; just start the engine with the vacuum hoses disconnected, let it warm up for two or three minutes, advance the throttle to the maximum operating position, connect the vacuum hoses and you are ready to extract water. We strongly suggest that the operator of the machine be well acquainted with the IICRC guidelines for Flood Extraction and with the various methods of carpet drying that are currently being used. It is also recommended that the machine operator be familiar with the local municipality's requirements for the proper disposal of waste water. Typically waste water is to be deposited in the city sewer system and never in a gutter or storm drain where it would eventually find it's way into a stream, river, lake, ocean or public water supply system.

⚠ WARNING

The manufacturer uses this symbol throughout the manual to warn of possible injury or death.

CAUTION

This symbol is used to warn of possible equipment damage.

NOTICE

This symbol is used to warn of regulatory or legal issues.

<u>Hours</u>	<u>Telephone Numbers</u>
Monday - Friday	(425) 775-7276 Parts
8:00 am to 5:00 pm	(425) 775-7275 Service
PACIFIC STANDARD TIME	(800) 426-4225 Parts / Service FAX

Precautions

▲ WARNING

ENGINE COOLING: Units employing internal combustion engines must not be enclosed within a van with doors and windows closed. Excessive temperatures within the engine will result in premature engine failure and a compromise of applicable warranty.

▲ WARNING

MOVING PARTS: Never touch any part of the machine that is in motion. Severe bodily injury may result.

▲ WARNING

HOT SURFACES: During the operation of this equipment, many surfaces on the machine will become very hot. When near the van for any reason care must be taken not to touch any hot surface, such as blower, engine, exhaust, etc.

▲ WARNING

HEARING PROTECTION: The Occupational Safety and Health Administration (OSHA) recommends the use of hearing protection when a technician is exposed to an *average* of 85 decibels (this is an average of exposure over an 8 hour period). This equipment can produce 85 decibels to a distance of 10 feet. Please check with your local state agencies to see if OSHA standards apply to your application.

▲ WARNING

NO SMOKING: It is unsafe to smoke in or around the vehicle.

▲ WARNING

CARBON MONOXIDE: This unit generates toxic fumes. Position the vehicle so that the fumes will be directed *away* from the job site. *Do not park where exhaust fumes can enter a building through open doors, windows, air conditioning units or kitchen fans.*

Boxxer H₂O

⚠ WARNING

TOXIC FUMES: Do not occupy the vehicle when the cleaning equipment is operating. Toxic fumes may accumulate inside a stationary vehicle.

⚠ WARNING

ENGINE EXHAUST: The engine exhaust from this product contains chemicals known to the State of California to cause cancer, birth defects or other reproductive harm.

⚠ WARNING

PORTABLE GAS TANK: Never operate this machine with a portable gas can inside the truck. Doing so increases the risk of a fire or explosion.

⚠ WARNING

TRANSPORTATION OF FUEL CONTAINERS: Transportation in a vehicle of any vented fuel container that presently has or has ever contained a flammable liquid is strictly forbidden by HydraMaster Corporation and by federal and state regulation.

CAUTION

THROUGH-FLOOR DRILLING: Be cautious when drilling holes through the van floor. Many vans have critical components mounted directly below the van floor that could be damaged by a misplaced drill bit. (See Product Support Bulletins 92102, 94062 and 94063 at the end of the manual.)

CAUTION

LEVEL OPERATION: During operation, van or trailer must be parked on level ground not to exceed + or - 10 degrees. Failure to insure proper leveling may prevent proper internal lubrication of engine and vacuum blower.

CAUTION

The machine cannot be run in the IDLE position for carpet or floor extraction. This will void the warranty.

CAUTION

EXHAUST SYSTEM: Do not allow flammable material (i.e. oil, fuel, plastic or wood products) to come in contact with the exhaust system.

Responsibilities

CAUTION

In Dodge vans the fuel tanks are located directly against the floor. Caution must be used when drilling any holes through the floor. (See Product Support Bulletin 94062 at the end of this manual.)

To purchase heavy duty 24- 60 amp hour battery and have the battery 'slow' charge if new.

CAUTION

If the battery is not fully charged, damage can occur to the engine charging regulator.

Reading of owner's manual: It is the purchaser's responsibility to read the unit operation manual and to familiarize himself with the information contained therein.

*Special attention should be paid to all **Cautions** and **Warnings**.*

The **Sales Representative's responsibilities** are:

ACCEPTANCE OF SHIPMENT:

1. If the unit shows any outward signs of damage, do not sign the delivery receipt until you have closely inspected the unit and noted any damage on the delivery receipt.
2. The salesman from whom you purchased your unit is responsible for supervising the correct installation of the unit in your vehicle and thoroughly training you in its operation, maintenance and precautions.

CORRECT INSTALLATION INCLUDES:

- Vehicle of proper load carrying capacity (recommendation: 3/4 ton).
- Installation of through-floor fittings for gasoline fuel lines.

Boxxer H₂O

- Placing the unit and recovery tank in your vehicle and securing them with bolts or tie down cleats.
- Connecting gasoline lines.
- Connecting the battery.
- Checking the vacuum blower and engine oil levels prior to starting the unit.
- Starting the unit to check the engine and see that all systems function normally.
- Checking all hoses, wands, etc. for correct operation.

TRAINING:

- A thorough review of the operation manual with purchaser.

Instruction and familiarization in:

- How to correctly start up and shut down the unit.
- How to correctly recover with the unit.
- Where and how often to check and change component oil levels.
- How the unit's systems work.
- How to troubleshoot the unit.
- How to do basic repairs.
- Safety precautions and their importance.
- A thorough review of the unit warranty and warranty procedures.

Vehicle Preparation

When selecting a truck, remember the preferable vehicle for a Boxxer H₂O installation is a cargo van with a heavy-duty suspension package and a 3/4 capacity. A 3/4 ton or larger capacity van, with a 2,400 pound payload capacity, is required.

TRUCK PREPARATION

The manufacturer recommends the installation of a spray-on bed liner in the vehicle prior to installation of machine.

CAUTION

Be cautious when drilling any holes through the van floor. Many vans have critical components mounted directly below the van floor that could be damaged by a misplaced drill bit. (See Product Support Bulletins 92101, 94062, and 94063 at the end of this manual.)

This provides 'metal to cushion' mounting rather than 'metal to metal' and makes for an attractive van interior. It is highly recommended to install roof vents in vehicles operated in hot weather locations. Roof vent positions are shown in Figure 1-1.

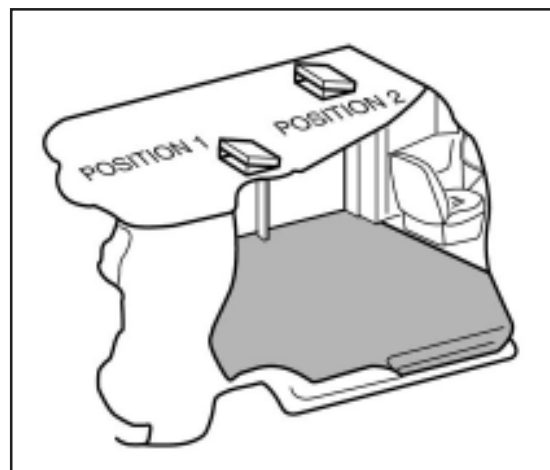

Figure 1-1 Roof Vents

Boxxer H₂O

PLACEMENT OF UNIT IN VEHICLE

There are two recommended unit placements (shown in Figure 1-2):

SIDE DOOR:

Most installations are side door. This provides rear access for accessories and hoses as well as unobstructed access to the component/working side of the machine, thus making it a bit easier to perform maintenance and/or repair without removing the unit from the truck.

REAR DOOR:

Although this location partly limits working access, it does direct the noise away from the cleaning site. Some cleaners in the colder areas prefer this location because it puts the weight over the rear wheels for better traction in ice and snow. Rear mounting requires the unit to be slid to the right side as far as possible.

This not only provides adequate working space on the component side of the unit but also improves weight distribution inside the van (engine and component weight line up over drive shaft). Also, it is physically easier to load the unit into the rear door due to the height of the van bed.



Figure 1-2 Recommended Placement

Machine Tie Down Cleats

Secure the machine to the floor of the van with the four tie down cleats provided. This safety measure will ensure that the machine will not slide inside the van. See the following illustration for the correct installation.

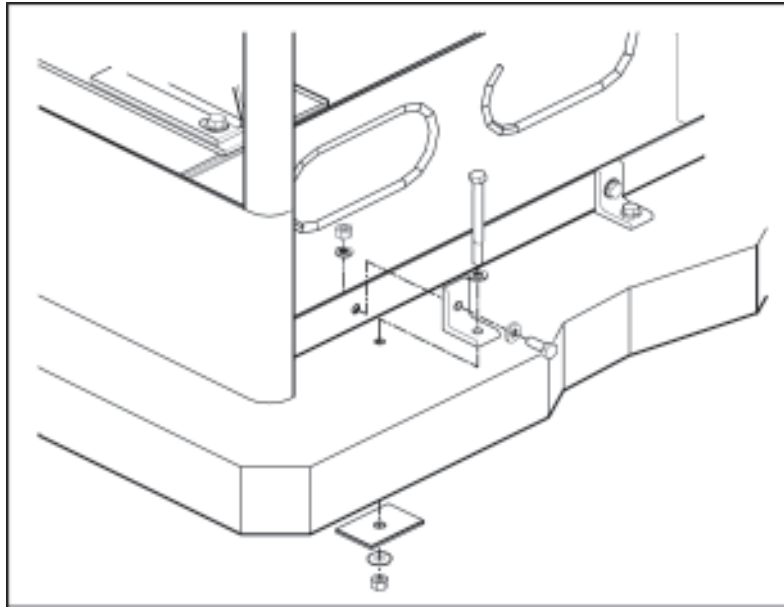

Figure 1-4 Installation Using Tie-down Cleats

Ensure that the machine is well secured to the floor of the van with the hardware supplied. A sudden stop or crash will cause the machine to rocket forward. Protect yourself and the machine. SECURE IT!

⚠ WARNING

It is recommended by the manufacturer that the exhaust from the front of the machine be vented down under the truck to prevent carbon monoxide from entering the job site. Always park the truck so the exhaust is blowing away from the job site.

The manufacturer also recommends the installation of aluminum vents in the truck roof to allow heat to escape.

⚠ WARNING

Never operate this machine with a portable gas can inside the truck. Doing so increases the risk of a fire or explosion.

Mount a fire extinguisher just inside the rear or side door for emergencies.

Boxxer H₂O

⚠ WARNING

Do not use a portable propane tank inside of the truck or van. Doing so may increase risk of fire or explosion.

⚠ WARNING

Transportation in a vehicle of any vented fuel container that presently holds or has ever held a flammable liquid is strictly forbidden by HydraMaster Corporation and by federal and state regulation.

⚠ WARNING

The engine exhaust from this product contains chemicals known to the State of California to cause cancer, birth defects or other reproductive harm.

High Altitude Operation Preparation

Although this unit has been factory adjusted, it may require additional adjustments to achieve optimum performance, for instance higher altitudes may require carburetor adjustment. When required, consult an authorized representative. Elevation plays a key role in how the machine will operate.

The factory setting of the machine is set for elevations from 0—3,000 feet. Any time the machine is operated above 3,000 feet there are two areas on the machine the *may* need adjustment.

The first area is the carburetor jet. The higher the elevation, the less air is provided to the fuel mixture. This will make the engine run 'rich', and, in turn will result in the loss of power, excessive heat in the exhaust, and carbon buildup in the exhaust system. The jet sizes vary per engine and elevation. Consult HydraMaster to obtain proper jet size.

Local Water Precautions

WASTE WATER DISPOSAL ADVISORY

There are laws in most communities prohibiting the dumping of recovered “gray” water from carpet cleaning in any place but a sanitary treatment system.

The extracted water recovered into your unit’s vacuum tank must be processed before being safe for streams, rivers and reservoirs.

NOTICE

IN ACCORDANCE WITH THE EPA, STATE AND LOCAL LAWS, DO NOT DISPOSE OF WASTE WATER INTO GUTTERS, STORM DRAINS, STREAMS, RESERVOIRS, ETC.

In most cases, an acceptable method of waste water disposal is to discharge into a municipal sewage treatment system after first filtering out solid material such as carpet fiber. Access to the sanitary system can be obtained through a toilet, laundry drain, RV dump, etc. Permission should first be obtained from any concerned party or agency.

One disposal method which usually complies with the law is to accumulate the waste water and haul it to an appropriate dump site. Another solution to the disposal problem is to equip your machine with an Automatic Pump-Out System. These systems are designed to remove waste water from the extractor’s recovery system and actively pump the water through hoses to a suitable disposal drain. Properly designed, they will continuously monitor the level of waste water and pump it out simultaneously to the cleaning operation. The hidden benefit of this process is that the technician does not have to stop his cleaning to empty the recovery tank.

HydraMaster produces an A.P.O. System available which can be ordered with new equipment or installed later.

The penalties for noncompliance can be serious. Always check local laws and regulations to be sure you are in compliance.

Machine Specifications

Frame:	Welded Steel
Weight:	572 lbs.
Engine:	Vanguard 27HP Briggs and Stratton Pressurized Oil System Spin-on Filter and Oil Cooler
Ignition:	Electronic, Keystart
Vacuum Blower:	Dominator 4007, Tuthill/M-D Tri-Lobe,
Instruments:	Hour Meter, Machine Runtime Keyed Ignition, Start/Stop Vacuum Gauge APO Switch Recovery Tank "Full" Light
Recovery Tank:	100 Gallon Aluminum, Epoxy Finish
Cleaning Wand:	Stainless Steel Replaceable Grip
Vacuum Hose:	2" Reinforced, 1-1/2" Reinforced.
Standard Equipment:	Machine Power Console Full Instrumentation Vacuum Recovery Tank 100 ft, 2" Vacuum Hose 10 ft, 1-1/2" Wand Whip Line Battery Box Van Decal Package Van Installation Kit Operation Manual HydraMaster Jacket

Machine Layout

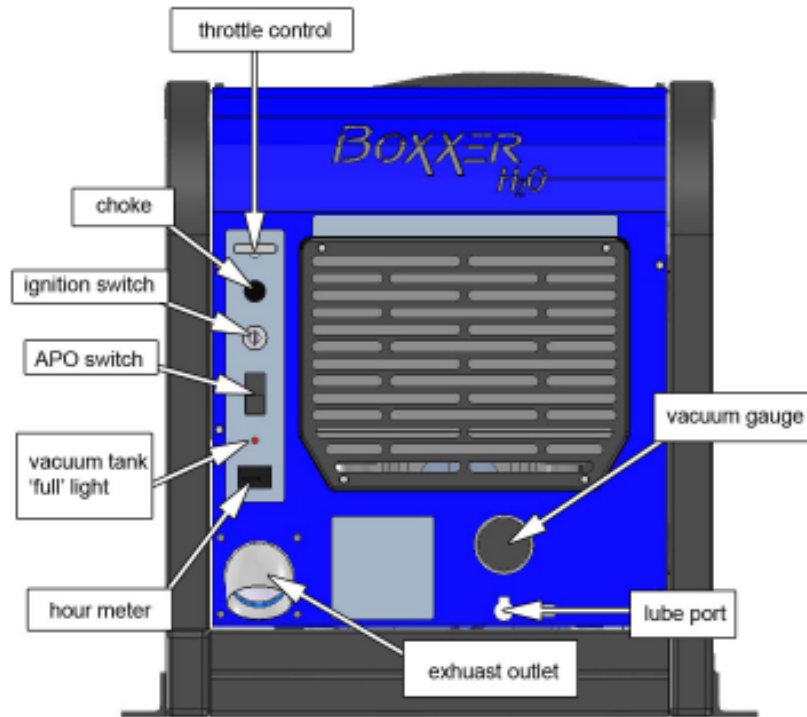

Throttle Control - Controls the speed of the engine.

Choke - Pull style cable for cold starts.

Ignition Switch - Main power control to the machine.

APO Switch - Activates/Deactivates Automatic Pump Out.

Vacuum Tank 'Full' Light - Lights up when vacuum tank is full.

Hour Meter - Displays total number of hours machine has been run during its lifetime.

Exhaust Outlet - Engine and blower exhaust outlet.

Lube Port - Allows blower to be lubricated.

Vacuum Gauge - Displays engine temperature and vacuum.

Operating Instructions

Perform daily and periodic maintenance as specified in this Owner's Manual.

CAUTION

The machine cannot be *run* in the "IDLE" position for water recovery. This will void the warranty.

CAUTION

Never run the machine on any speed other than full throttle during water extraction. Extracting at any other speed will void the warranty.

Start Up

Flood Extraction

1. Start the engine with the THROTTLE cable to the "IDLE" position. Allow the machine to run in idle for **2 - 3 minutes to warm up**.
2. Connect required length of hoses.
3. Connect wand or tool.
4. Pull the THROTTLE cable to the "HIGH" position.
5. If used, turn PUMP OUT switch to "ON" .
6. Commence water extraction.

Shut Down

1. Remove the vacuum hose.
2. At this time, the blower should be lubricated with an oil-based lubricant. See the blower manufacturer's manual or the maintenance section for lubrication information.
3. Lower the engine RPMs to idle.
4. Turn the key off.
5. Drain the vacuum tank. The vacuum filter should be cleaned prior to mobilization of the van.

NOTICE

In accordance with the EPA, state and local laws, **do not dispose of** waste water into gutters, storm drains, streams, reservoirs, etc.

6. Perform daily maintenance as prescribed in this manual.

Boxxer H₂O

This page intentionally left blank

Machine Maintenance

To avoid costly repairs and downtime, it is imperative to develop and practice good maintenance procedures from the beginning. These procedures fall into daily, weekly, monthly and quarterly increments, and are outlined below. All recommended maintenance must be performed by competent service personnel.

Important: Record the date and machine hours on the maintenance log.

We have provided a maintenance log for your convenience at the end of this section. Records of maintenance must be kept and copies may be required to be furnished to HydraMaster before the warranty is honored. It is recommended that you affix a copy of the log on the vehicle door near your unit for convenience and to serve as a maintenance reminder.

OPERATIONAL MAINTENANCE

DAILY:

- Check engine oil level.
- Visually inspect machine for loose wires, oil leaks, etc.
- Lubricate blower with an oil based lubricant through blower inlet.

WEEKLY:

- Inspect vacuum tank s/s filter and filter basket for tears, holes, etc. Clean, repair or replace as needed.
- One time change of oil and oil filter after first 50 hours of use.
- Check oil level in blower.
- Check drive system screws. Tighten as needed.
- Check all nuts and bolts. Tighten as needed.
- Inspect vacuum relief valve. Clean and lubricate as necessary.
- Clean vacuum tank thoroughly with high pressure washer.
- Check wiring for chafing.
- Change engine oil (every 100 hrs.).

Boxxer H₂O

MONTHLY:

- Change oil filter (every other oil change).

CAUTION

It is important to use only Briggs oil filters. Even though an aftermarket filter may fit, the internal by-pass system may not be compatible with the Briggs engine resulting in low oil pressure.

- Check engine air cleaner filter. Clean as necessary.
- Check water level in battery. Clean connections as needed.

QUARTERLY:

- Check fuel lines.
- Clean and gap spark plugs.
- Check drive coupler for cracks or wear. Replace as necessary.
- Change oil in blower.

500 HOURS:

- Check coupler element between the engine and the blower, replace as necessary.

OVERALL MACHINE MAINTENANCE

Maintaining the original appearance of your unit is important for two reasons:

1. It represents a big dollar investment for your recovery business and its appearance should reflect that fact. A dirty machine is not professional.
2. Maintenance, troubleshooting, and repair is much easier to accomplish on a clean, well maintained unit. Regular cleaning of the machine offers you an opportunity to visually inspect all facets of the machine and spot potential problems before they occur.

The following maintenance is recommended by the manufacturer at the frequency indicated.

AFTER EACH JOB

- Check recovery tank, s/s filter and filter basket as required.

DAILY

- Wipe machine down thoroughly with a damp cloth.
- Flush recovery tank out thoroughly.
- Empty filter basket and inspect for rips, tears, etc. Replace as needed.
- Remove, thoroughly clean and reinstall stainless steel filter screen in recovery tank.
- Inspect and clean vacuum slot on recovery wand.
- Check wand head for sharp edges that could tear carpet. File down as needed.
- Clean wand to maintain original appearance.
- Wipe down vacuum hoses as needed.
- Visually inspect hoses for cuts, etc.

WEEKLY

- Wipe down entire unit as needed.
- Apply good coat of auto wax to all painted surfaces inside and out, and to control panel.
- Thoroughly clean recovery tank using high pressure water.
- Remove stainless steel filter in recovery tank and thoroughly clean, removing all lint buildup. Inspect for damage and reinstall.
- Remove filter basket. Thoroughly clean and reinstall.
- Apply light coat of auto wax to wand.
- Thoroughly clean vacuum hoses including hose cuffs.
- Inspect for wear or damage to hoses and quick connect fittings.

Boxxer H₂O

This page intentionally left blank

Machine Assemblies and Parts Lists

Figure 5-1 **Machine Assembly - Front View - Left Side**
D-6800 Rev -

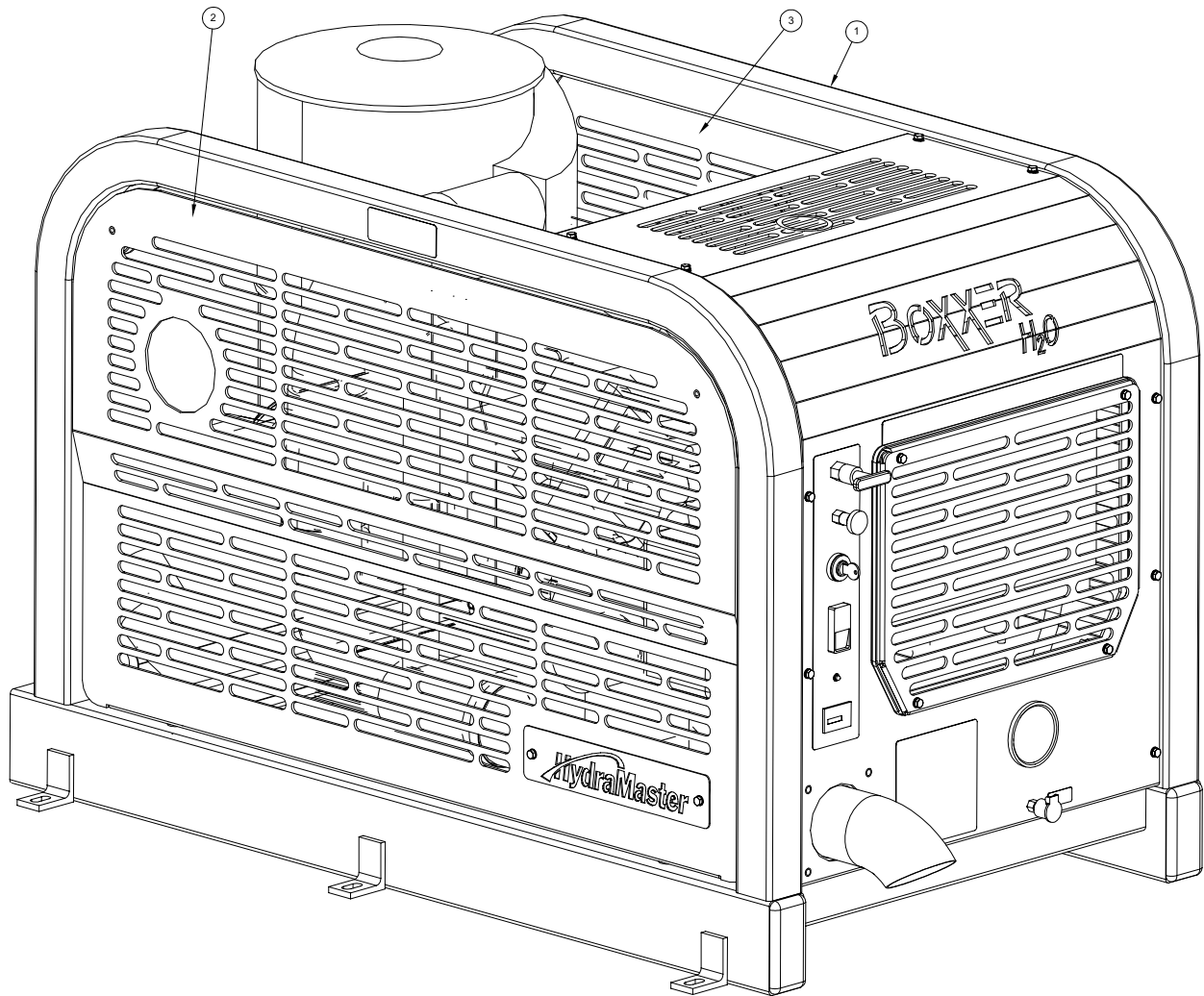

Boxxer H₂O

Figure 5-2 Machine Assembly - Front View - Right Side
D-6800 Rev -

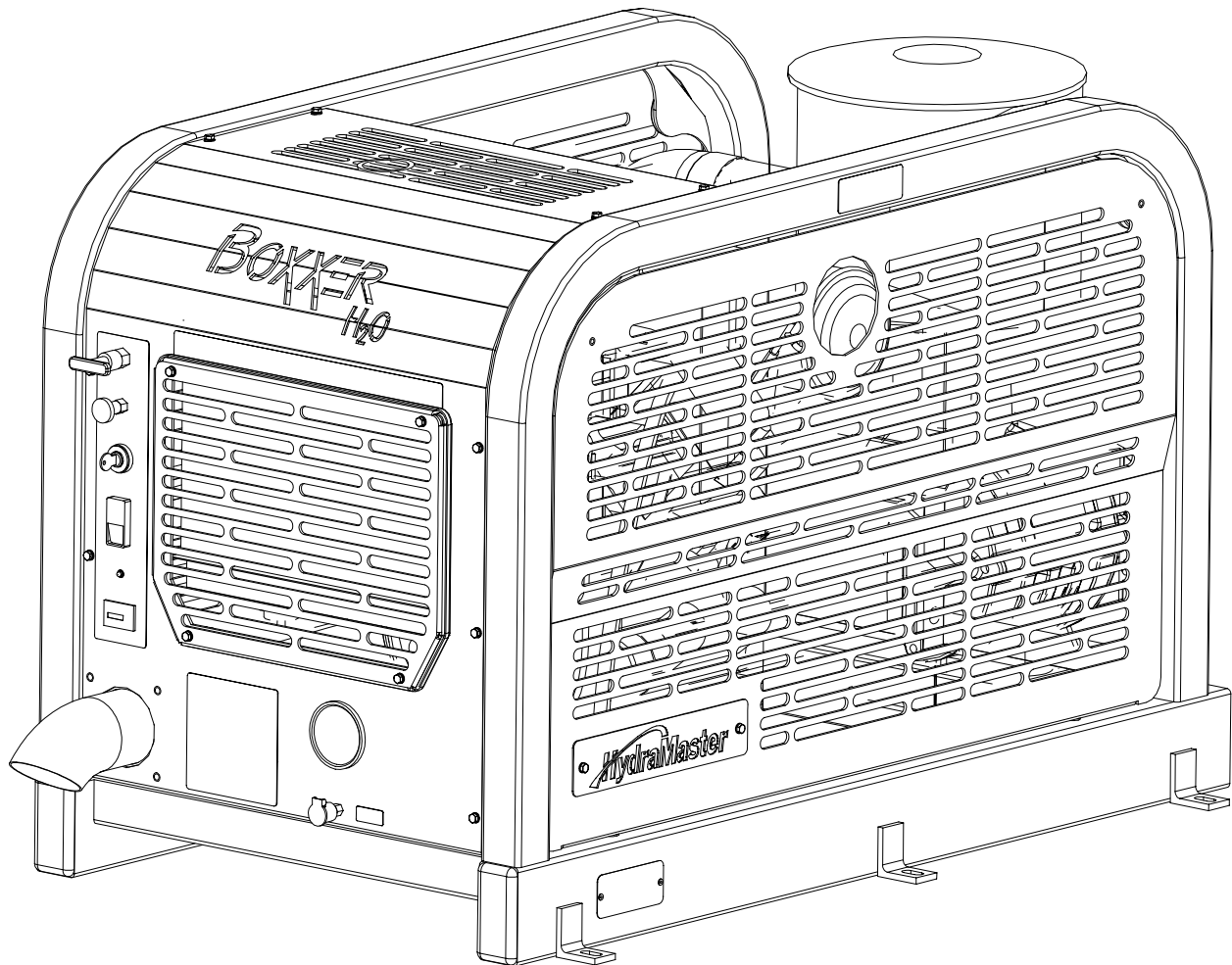

Machine Assembly Parts List

Item	Part Number	Description	Qty
1	610-001-036	Assembly, Frame - Boxxer H2O (Fig. 5-3 & 5-5)	1
2	610-050-033	Assembly, Machine Left Side Cover (Fig. 5-9)	1
3	610-050-033	Assembly, Machine Right Side Cover (Fig. 5-10)	1

Figure 5-3 Frame Assembly - Front View - Left Side
D-6801 Rev -

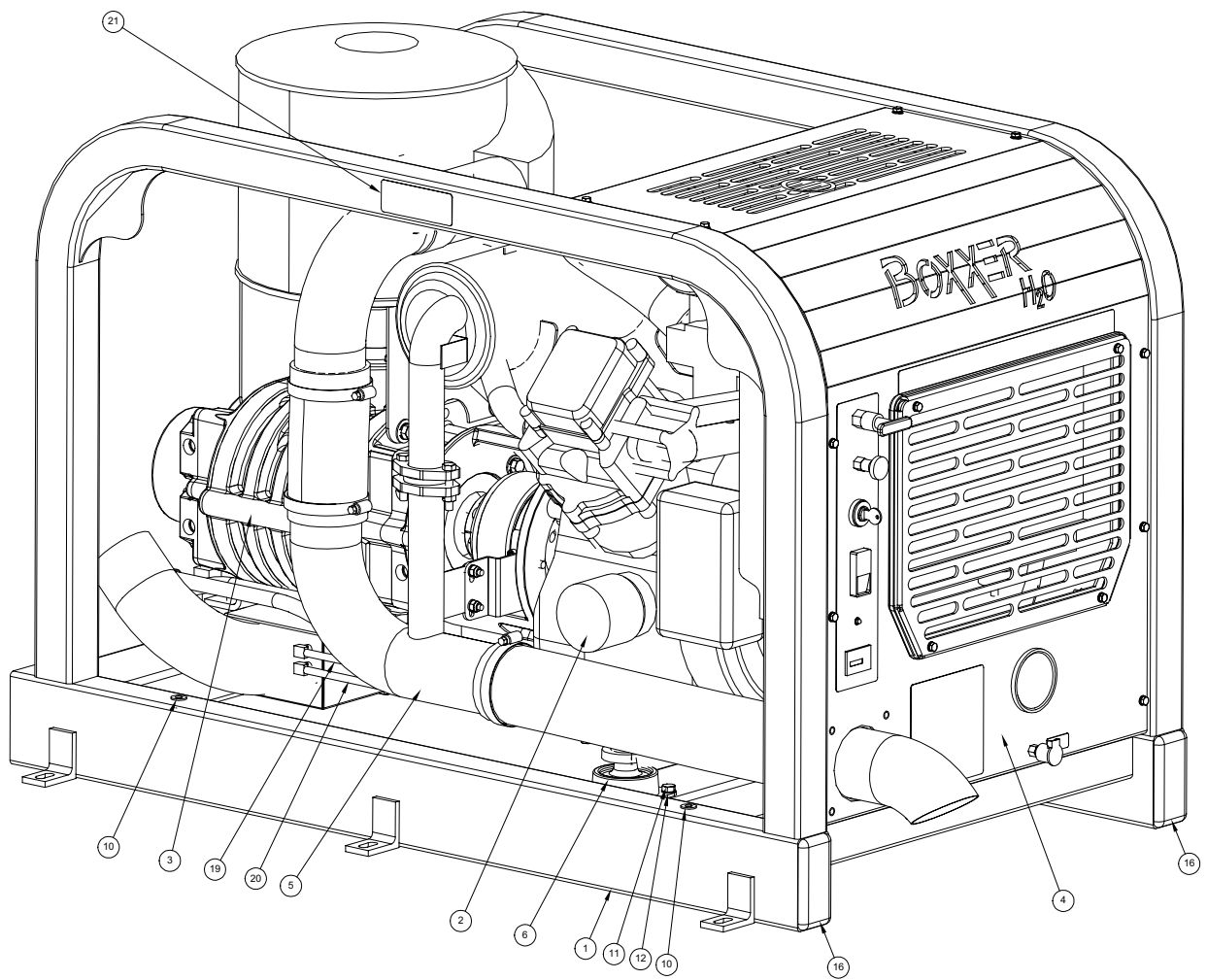

Boxxer H₂O

Figure 5-4 Frame Assembly - Front View - Right Side
D-6801 Rev -

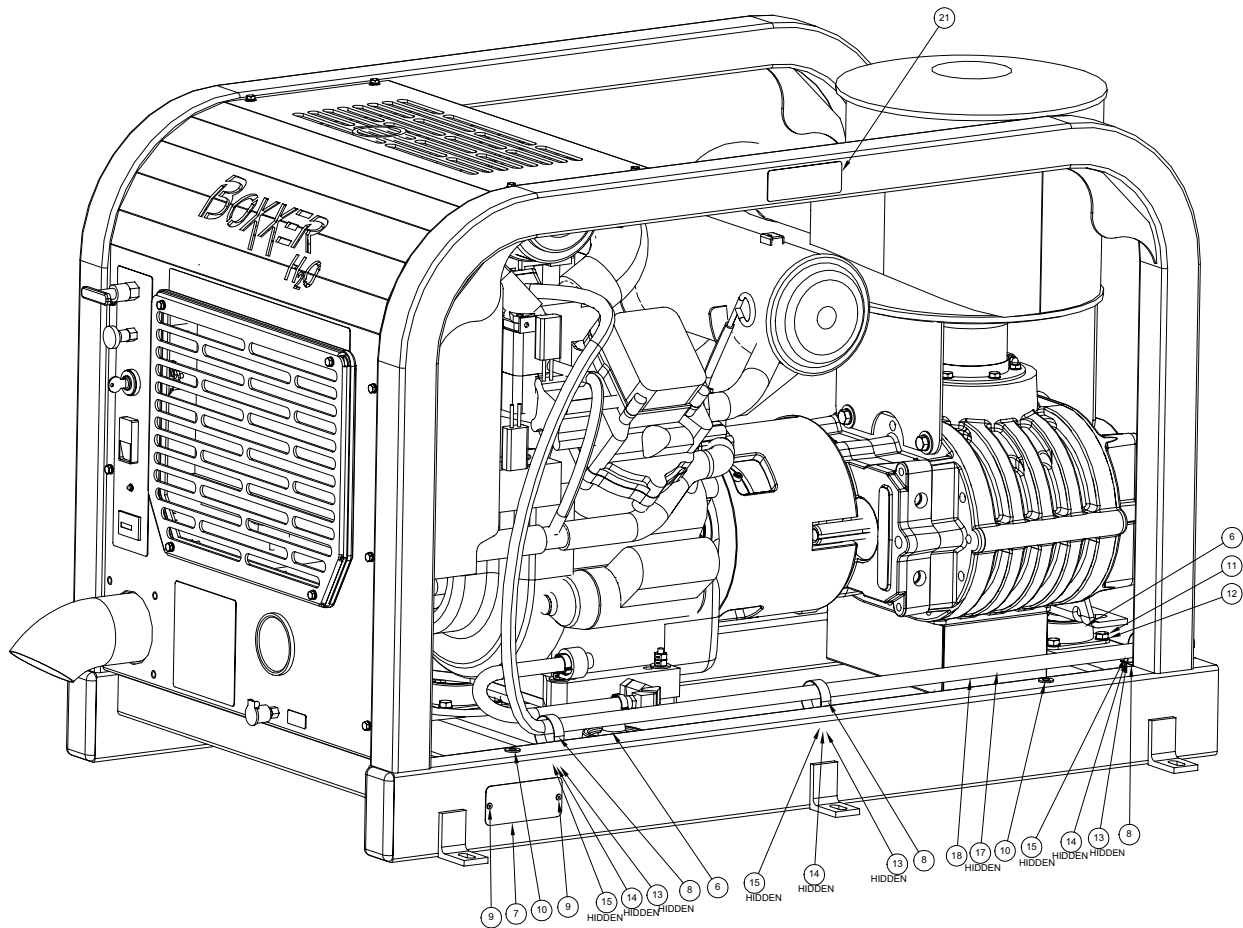

Frame Assembly Parts List

Item	Part Number	Description	Qty
1	000-055-186	Frame, Weldment - Boxxer H2O	1
2	610-003-036	Assembly, Engine - Boxxer H2O (Fig. 5-5)	1
3	610-002-036	Assembly, Blower - Boxxer H2O (Fig. 5-6)	1
4	610-020-036	Assembly, Dash Boxxer H2O (Fig. 5-7)	1
5	601-003-036	Assembly, Exhaust - Boxxer H2O (Fig. 5-8)	1
6	000-092-017	Mount, Rubber Isolator - Boxxer H2O	3
7	000-105-012	Plate, Machine Serial I.D.	1
8	000-033-053	Clamp, 1-1/2" Cushion Loop	3
9	000-140-015	Rivet, 1/8" x 1/4" Lg. Pop	2
10	000-020-063	Bushing, Snap, 0.55" O.D. x 0.312" I.D.	4
11	000-143-013	Screw, 5/16"-18UNC x 1.00" Lg. Grade 8	12
12	000-174-018	Washer, 5/16" Lock	12
13	000-174-001	Washer, #10 Flat	3
14	000-174-014	Washer, #10 Lock	3
15	000-143-126	Screw, #10-24UNC x 0.50" Lg. Hex Head	3
16	000-027-033	Cap, Frame End - Raw	2
17	000-068-660	Hose, 1/4" I.D. Trident Fuel - Bulk	1
18	000-131-055	Insulation, Hi Temp Sleeving - Bulk	1
19	000-068-030	Hose, 5/32" I.D. Vacuum - Bulk	1
20	000-068-030	Hose, 5/32" I.D. Vacuum - Bulk	1
21	000-081-036	Label, ANSI Warning Text Only	2

Boxxer H₂O

Figure 5-5 Engine Assembly

D-6802 Rev A

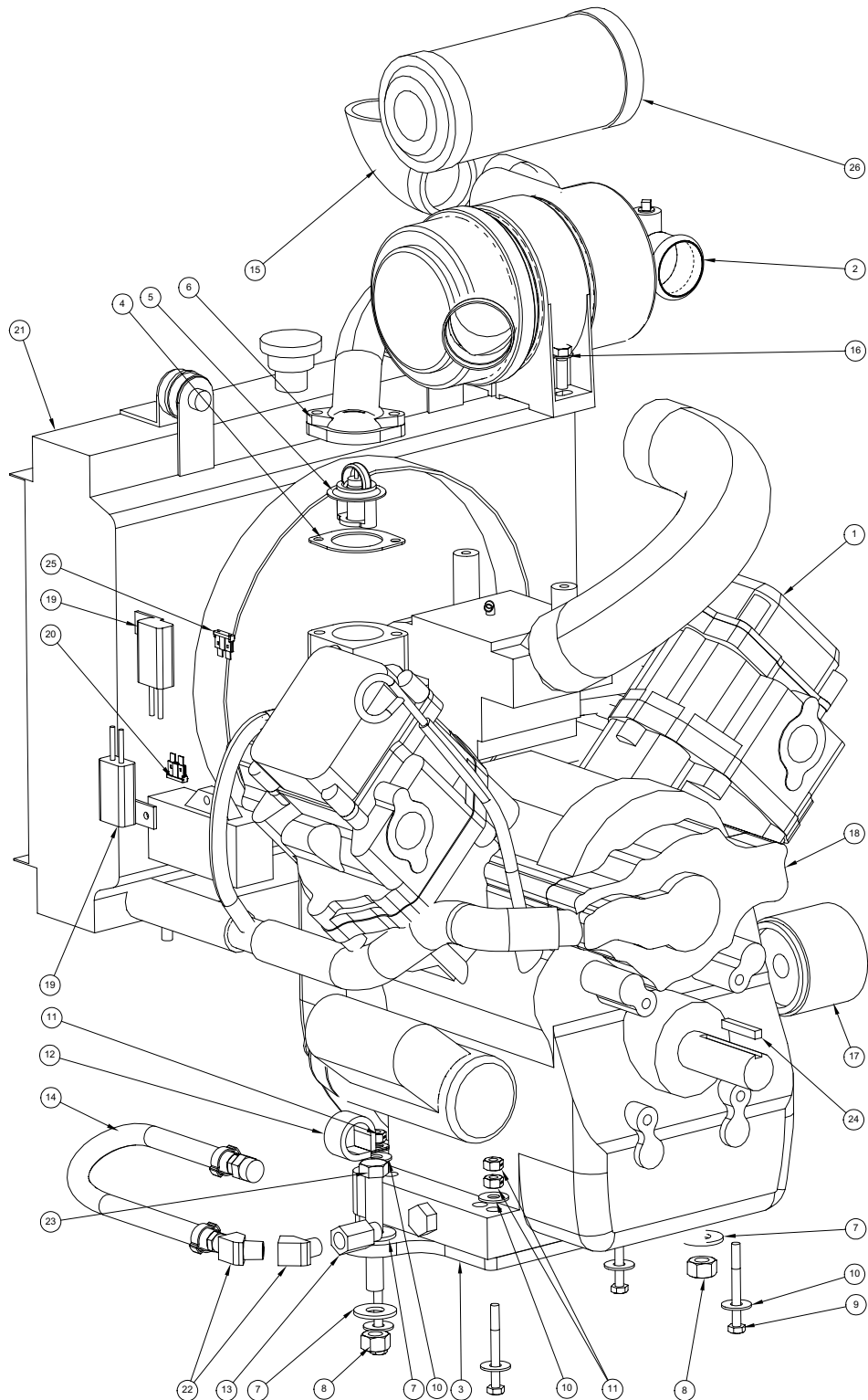

Engine Assembly Parts List

Item	Part Number	Description	Qty
1	000-047-026	Engine, Briggs & Stratton 27HP	1
2	000-047-026	Air Cleaner - Daihatsu Engine	1
3	000-092-011	Mount, Engine 27 B&S	1
4	000-057-050	Gasket, Thermostat Housing Daihatsu Engine	1
5	000-047-026	Thermostat, Stock B&S 27HP	1
6	000-047-026	Thermostat Housing, B&S 27 HP Stock	1
7	000-174-007	Washer, 1/2" Flat	4
8	000-094-037	Nut, 1/2"-13UNC Hex 2-Way Locking - z/p	2
9	000-143-568	Screw, 5/16"-18UNC x 2.50" Lg. Hex Head Grade 8	4
10	000-174-004	Washer, 5/16" Flat	8
11	000-094-081	Nut, 5/16"-18UNC Hex 2-Way Locking	5
12	000-033-117	Clamp, 1" Cushion Loop w/ 7/16" Mount Hole	1
13	000-052-063	Bushing, 14mm x 1/4" NPT Engine Oil Drain Adapter	1
14	000-068-221	Hose, Engine Oil Drain	1
15	000-068-595	Hose, 1.75" x 18.25" x 90 Molded Radiator	1
16	---	Screw, 8mm x 25mm Lg. Hex Head Washer	2
17	000-049-014	Filter, 16HP Oil - All B & S	1
18	000-111-171	Pump, B&S 27 HP Water	1
19	000-056-006	Fuse Holder, Inline Weather Proof	2
20	000-056-011	Fuse, 30 AMP Plug In	1
21	000-113-007	Radiator, 27 HP B & S Engine	1
22	000-052-082	Elbow, 1/4" NPT Street x 45°	2
23	000-143-155	Screw, 1/2"-13UNC x 3.50" Lg. Hex Head	2
24	000-077-010	Key, 1/4" x 1-1/2" Lg. Class 2 Fit	1
25	000-056-005	Fuse, 25 AMP Plug In	1
26	000-049-063	Filter, Replacement - Engine Air Daihatsu	1

Boxxer H₂O

Figure 5-6 **Blower Assembly**

D-6803 Rev A

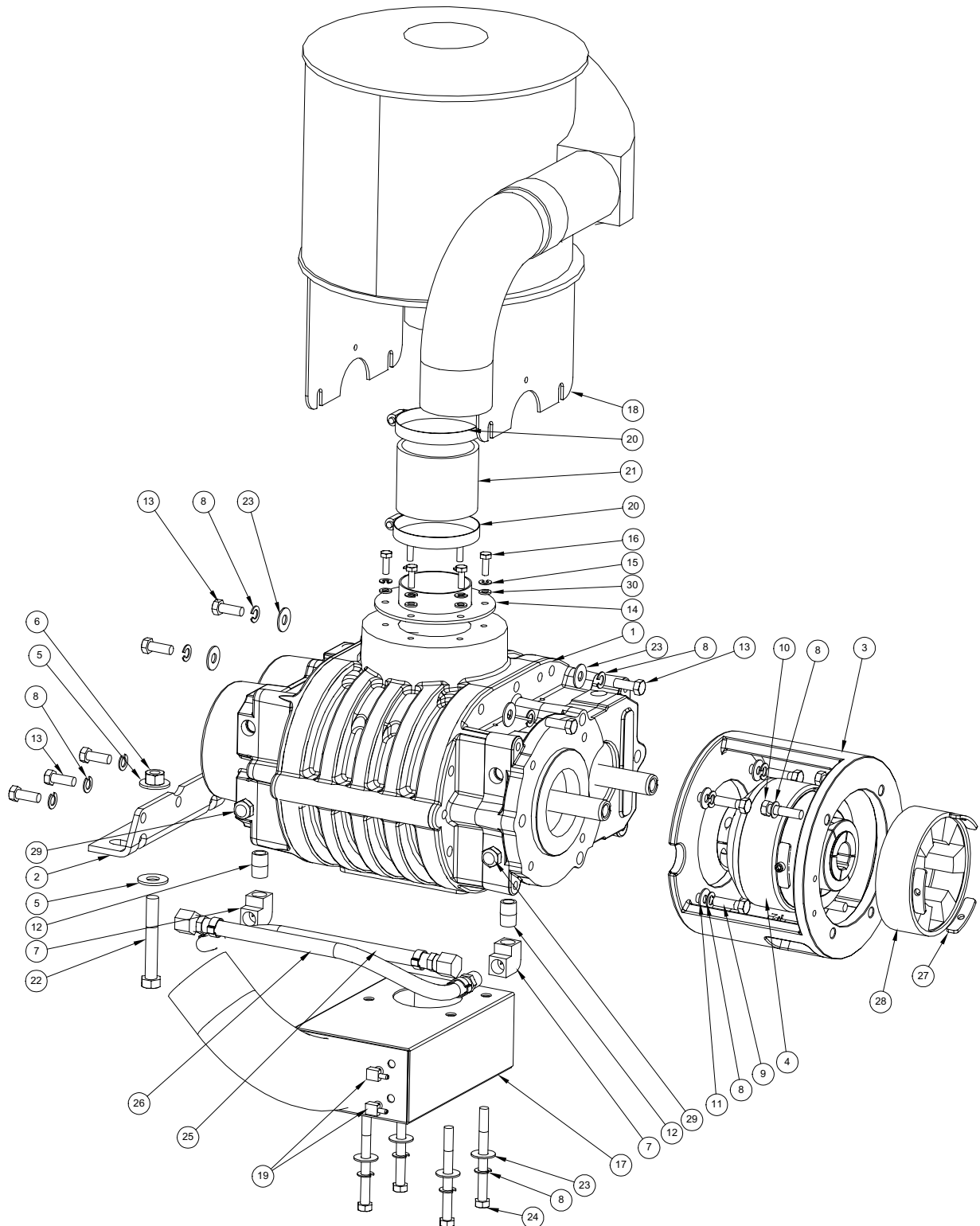

Blower Assembly Parts List

Item	Part Number	Description	Qty
1	000-111-167	Blower, MD 4007 C-Face Dual Shaft	1
2	000-015-814	Bracket, Dominator Mounting	1
3	000-042-063	Housing, Bell - Modified	1
4	000-039-053	Coupler, 50 Series	1
5	000-174-007	Washer, 1/2" Flat	2
6	000-094-037	Nut, 1/2"-13UNC Hex 2-Way Locking - Z/P	1
7	000-052-142	Elbow, 3/8" FPT x FPT	2
8	000-174-021	Washer, 3/8" Lock	19
9	000-143-025	Screw, 3/8"-16UNC x 1.25" Lg. Hex Head Grd 8	4
10	000-143-200	Screw, 3/8"-16UNC x 1.50" Lg. Grade 8	4
11	000-174-004	Washer, 5/16" Flat	4
12	000-052-077	Nipple, 3/8" NPT Close	2
13	000-143-018	Screw, 3/8"-16UNC x 1.00" Lg. Grade 8	7
14	000-001-115	Adapter, Blower Flange To 3" M Slip	1
15	000-174-019	Washer, 1/4" Lock	6
16	000-143-001	Screw, 1/4"-20UNC x 0.75" Lg. Hex Head	6
17	000-013-069	Box, Blower Collector - Weldment	1
18	000-093-104	Silencer, Weldment	1
19	000-052-106	Insert, 1/8" NPT x 5/32" Barb x 90°	2
20	000-033-013	Clamp, Size #48 Hose	2
21	000-068-398	Hose, 3" I.D. x 3 Ply Silicone	1
22	000-143-155	Screw, 1/2"-13UNC x 3.50" Lg. Hex Head	1
23	000-174-005	Washer, 3/8" Flat	8
24	000-143-139	Screw, 3/8"-16UNC x 4.00 Lg. Grd 8	4
25	000-068-219	Hose, Drain	1
26	000-068-219	Hose, Drain	1
27	000-078-424	Kit, Metal Ring Retainer 3 Pc. (Replacement)	1
28	000-152-010	Sleeve, 50 Series Split (Replacement)	1
29	000-027-112	Plug, Oil Sight Glass Tuthill Blower	2
30	000-174-003	Washer, 1/4" Flat	6

Boxxer H₂O

Figure 5-7 Dash Assembly
D-6804 RevA

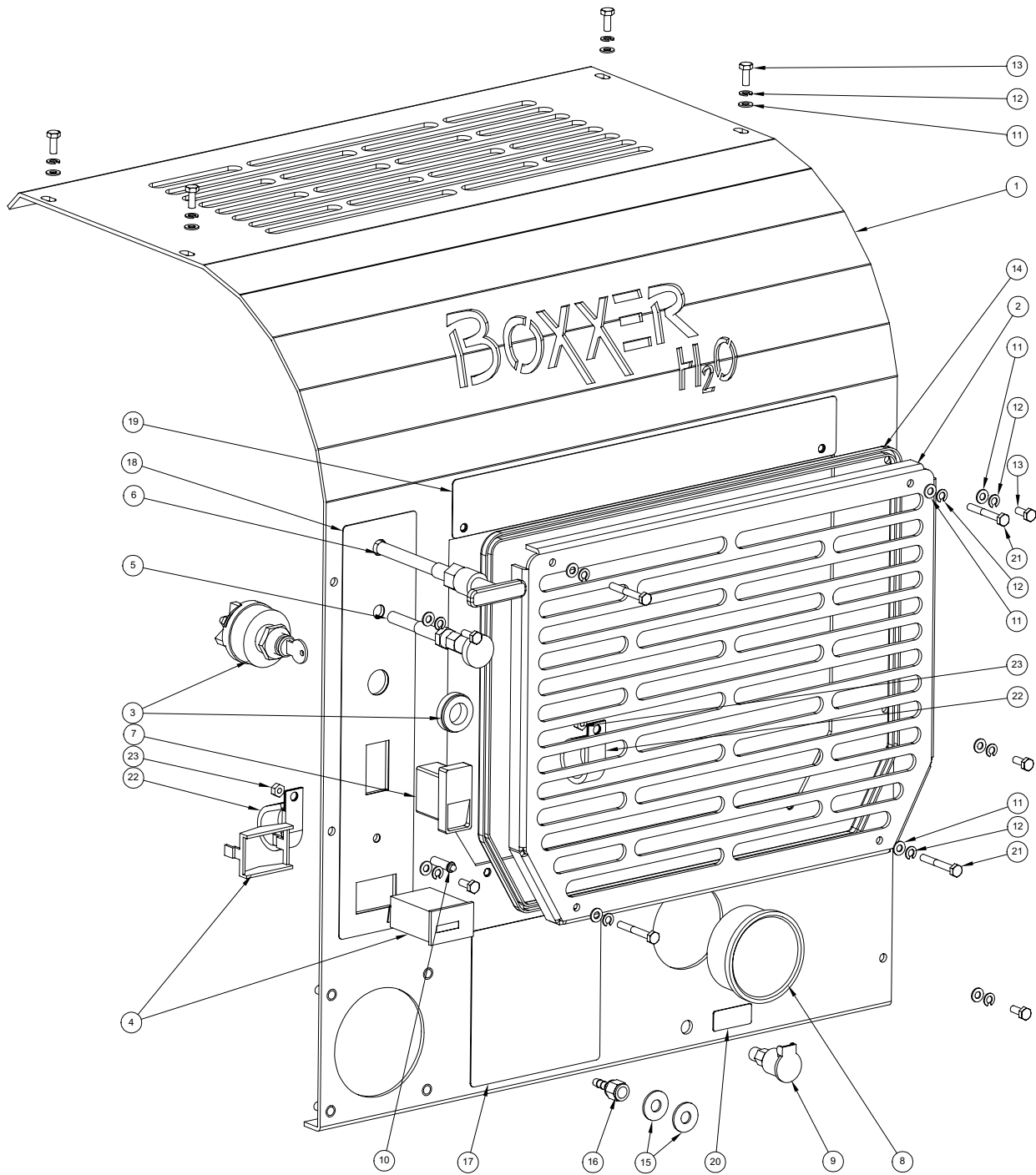

Dash Assembly Parts List

Item	Part Number	Description	Qty
1	000-100-163	Panel, Dash	1
2	000-100-145	Panel, Grill	1
3	000-157-008	Switch, Ignition	1
4	000-074-018	Meter, Rectangular w/o Bezel	1
5	000-025-002	Cable, Choke (3 Foot)	1
6	000-025-020	Cable, Throttle Kohler	1
7	000-157-040	Switch, 20 AMP Rocker	1
8	000-074-017	Guage, 0-30" Hg Vac. 2 1/2" HydraMaster Face	1
9	000-052-272	Cup, Gravity Feed Oil Blower Lubrication Port	1
10	000-084-011	Light, Red Led Indicator Mini	1
11	000-174-001	Washer, #10 Flat	13
12	000-174-014	Washer, #10 Lock	13
13	000-143-126	Screw, #10-24UNC x 0.50" Lg. Hex Head	9
14	000-131-131	Trimlock, 3/8" x 1/8" Groove - Bulk	1
15	000-174-032	Washer, 3/8" Flat	2
16	000-052-096	Insert, #F23 (1/8" FPT x 3/16" Barb)	1
17	000-081-036	Label, ANSI Warning	1
18	000-081-036	Label, Dash Controls	1
19	000-081-036	Label, Water Recovery System	1
20	000-081-036	Label, Lube Port - Boxxer H2O	1
21	000-143-133	Screw, #10-24UNC x 1.50" Lg. Hex Head	4
22	000-033-057	Clamp, 1" Cushion Loop	2
23	000-094-034	Nut, #10-24UNC Nylock	2

Boxxer H₂O

Figure 5-8 Exhaust Assembly
D-6805 Rev -

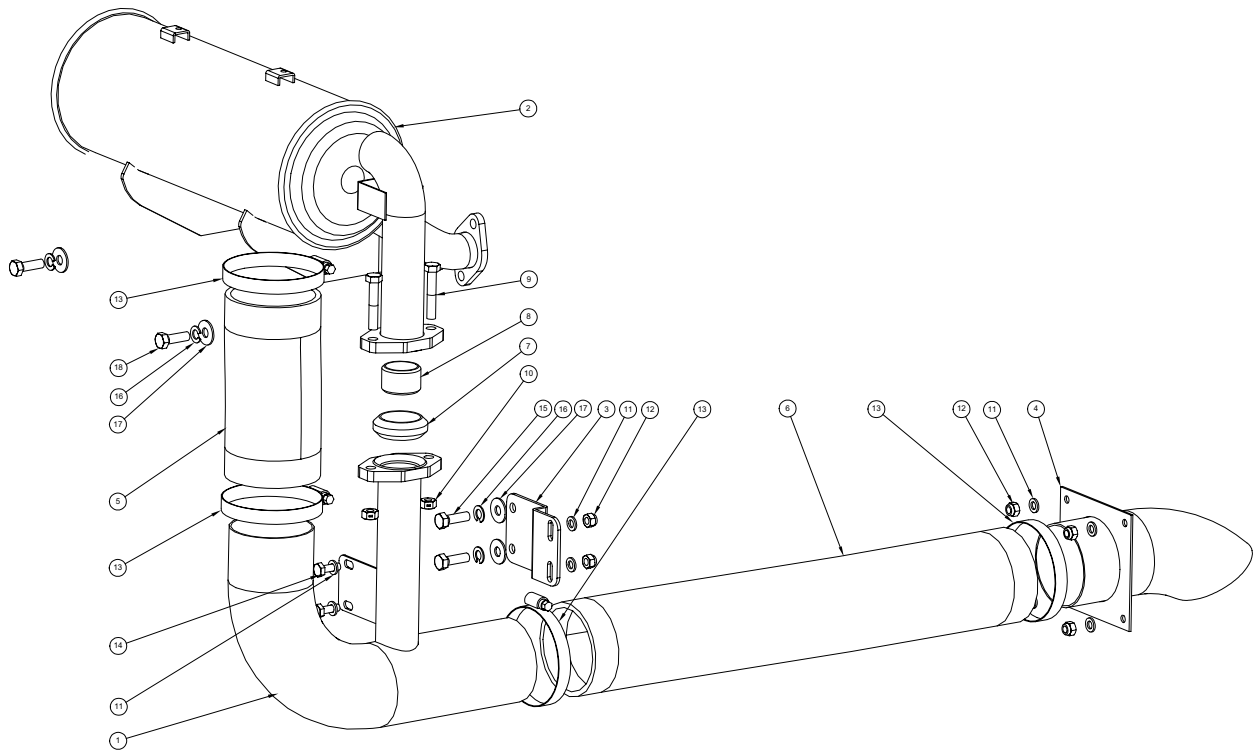

Exhaust Assembly Parts List

Item	Part Number	Description	Qty
1	000-125-223	Tube, Lower Exhaust - Boxxer H2O	1
2	000-093-103	Muffler, Weldment - Boxxer H2O	1
3	000-015-931	Bracket, Exhaust Support - Boxxer H2O	1
4	000-001-098	Adapter, Exhaust Turndown - Weldment	1
5	000-068-398	Hose, 3" I.D. x 3 Ply Silicone - Bulk	1
6	000-068-398	Hose, 3" I.D. x 3 Ply Silicone - Bulk	1
7	000-057-177	Gasket, Exhaust Donut 1.50"	1
8	000-125-128	Tube, 1-3/8" O.D. x 1/8" Wall x 7/8" Long	1
9	000-143-124	Screw, 5/16"-18UNC x 1.75" Lg. Hex Head	2
10	000-094-081	Nut, 5/16"-18UNC Hex 2-Way Locking	2
11	000-174-003	Washer, 1/4" Flat	8
12	000-094-009	Nut, 1/4"-20UNC Hex Nylock	6
13	000-033-013	Clamp, Size #48 Hose	4
14	000-143-001	Screw, 1/4"-20UNC x 0.75" Lg. Hex Head	2
15	000-143-013	Screw, 5/16"-18UNC x 1.00" Lg. Grade 8	2
16	000-174-018	Washer, 5/16" Lock	4
17	000-174-004	Washer, 5/16" Flat	4
18	000-143-187	Screw, 8mm x 25mm Lg. Grade. 10.9 Hex Head	2

Boxxer H₂O

Figure 5-9 Machine Left Side Cover Assembly

D-5587 Rev -

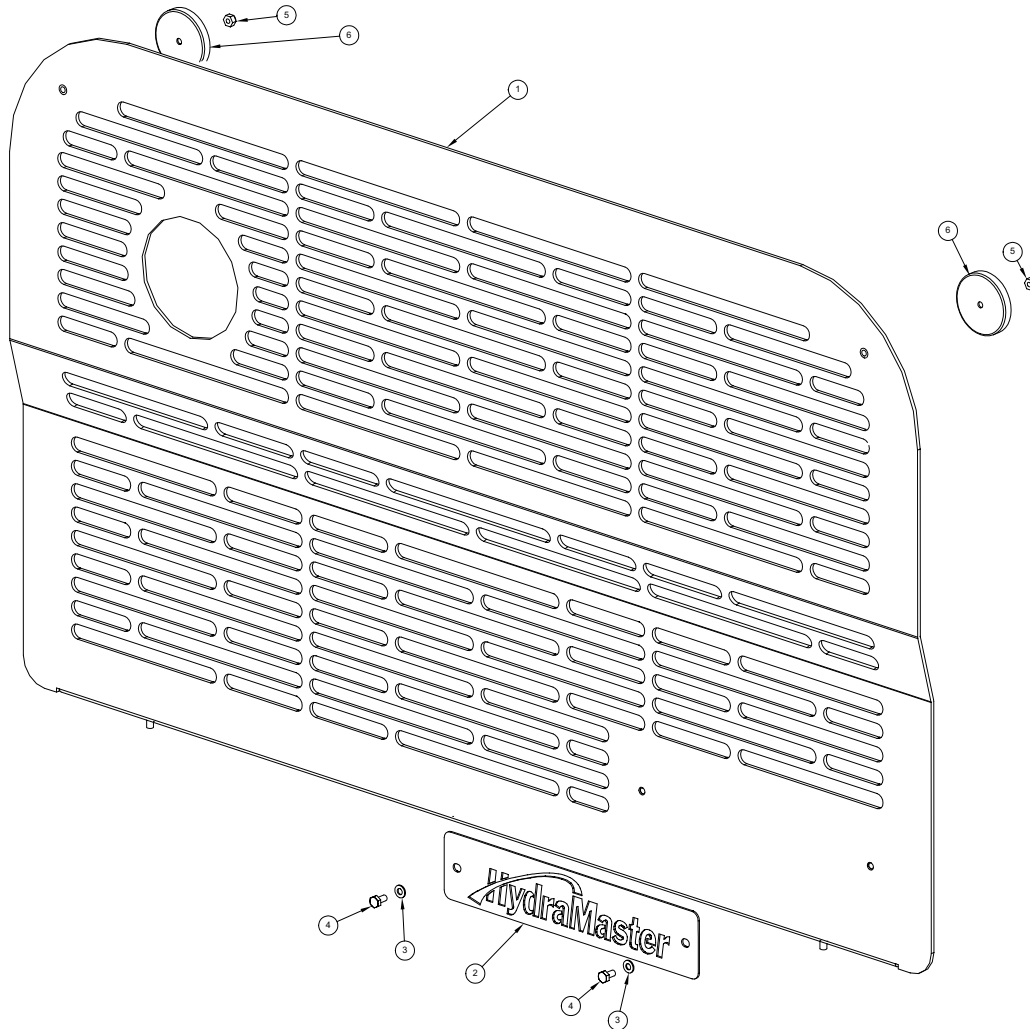

Machine Left Side Cover Assembly Parts List

Item	Part Number	Description	Qty
1	000-041-417	Cover, Left Side Machine - Boxxer 427	1
2	000-105-313	Plate, Hydramaster Name- Roto Tank	1
3	000-174-001	Washer, #10 Flat	2
4	000-143-166	Screw, #10-24UNC x 0.38" Lg. Hex Head	2
5	000-094-034	Nut, #10-24UNC Nylock	2
6	000-089-003	Magnet, Treadmaster	2

Figure 5-10 Machine Right Side Cover Assembly

D-5762 Rev -

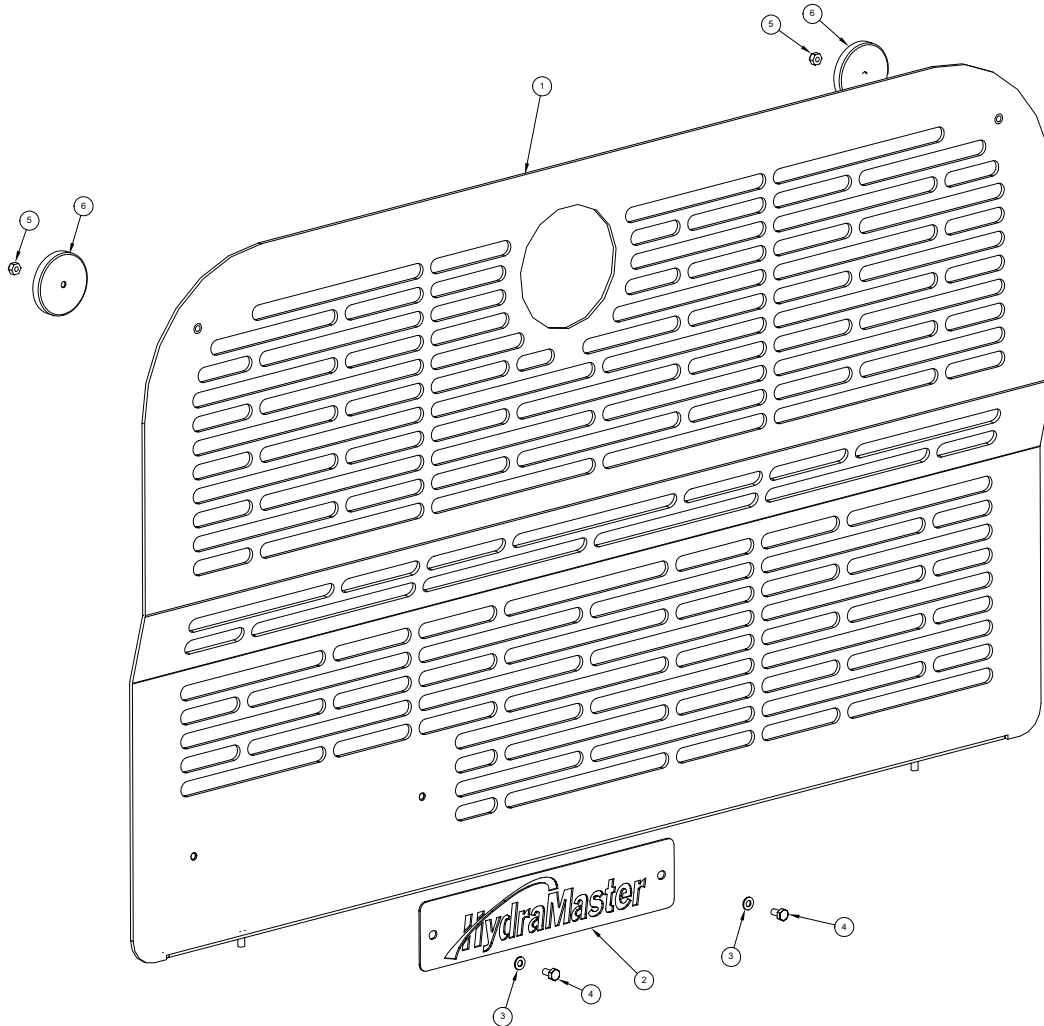

Machine Right Side Cover Assembly Parts List

Item	Part Number	Description	Qty
1	000-041-419	Cover, Right Side Machine - Boxxer 427	1
2	000-105-313	Plate, Hydramaster Name- Roto Tank	1
3	000-174-001	Washer, #10 Flat	2
4	000-143-166	Screw, #10-24UNC x 0.38" Lg. Hex Head	2
5	000-094-034	Nut, #10-24UNC Nylock	2
6	000-089-003	Magnet, Treadmaster	2

Boxxer H₂O

Figure 5-11 100 Gallon Universal Recovery Tank Assembly
D-7149 Rev A

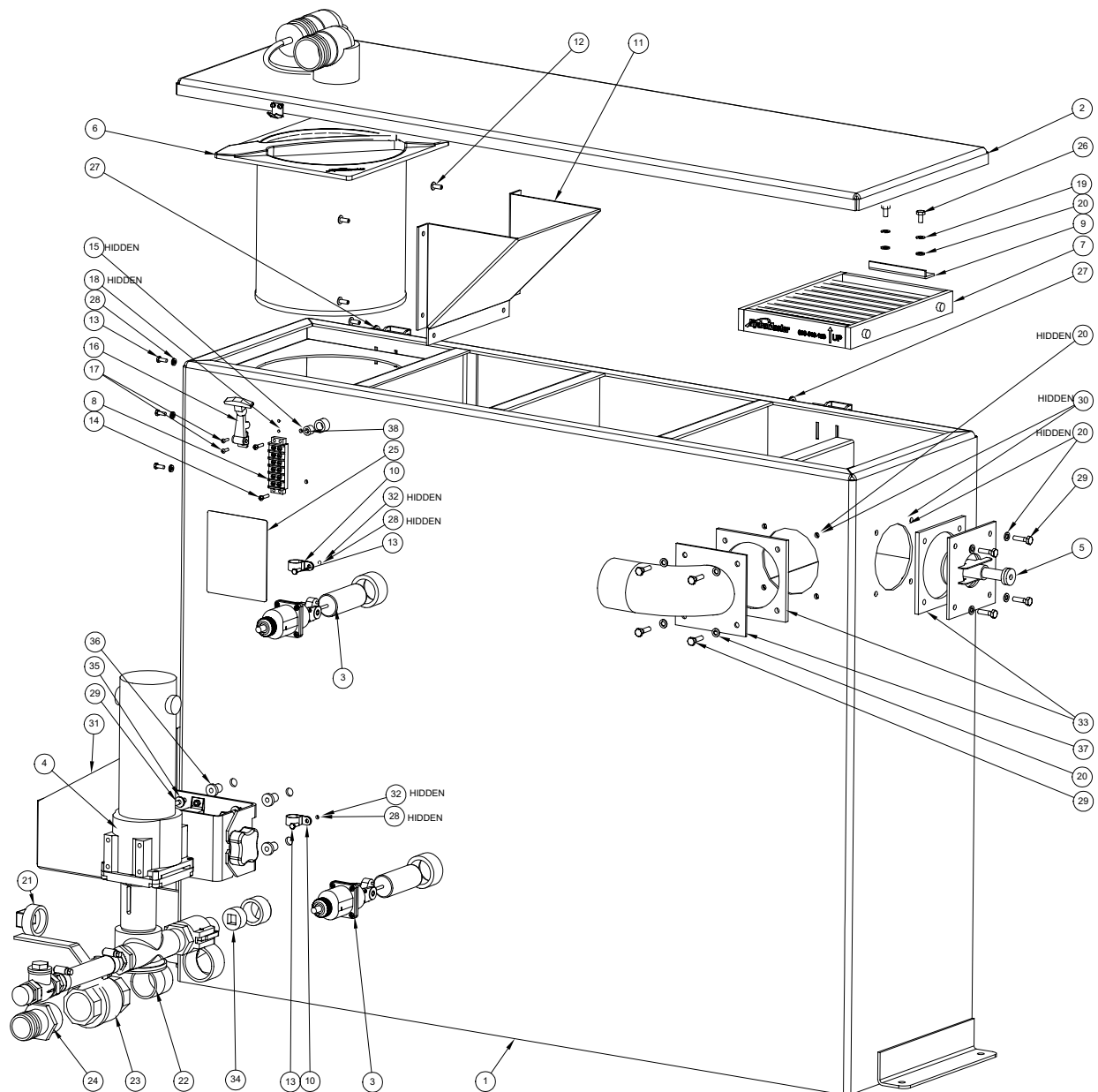

100 Gallon Universal Recovery Tank Assembly Parts List

Item	Part Number	Description	Qty
1	000-159-129	Tank, 100 Gallon Universal Recovery - Weldment	1
2	Fig. 5-12	Assembly, Recovery Tank Cover - 100 Gallon	1
3	000-157-090	Float, Lever Switch	2
4	000-079-091	Kit, Dura-Flow APO - Production (Fig. 5-14)	1
5	Fig. 5-13	Assembly, Vacuum Relief Valve	1
6	000-049-152	Filter, Recovery Tank Basket	1
7	000-049-153	Filter, Flat - Recovery Tank	1
8	000-012-002	Block, 6 Post Terminal	1
9	000-015-932	Bracket, Flat Filter Securing - Universal Recovery Tank	1
10	000-033-023	Clamp, 3/4" Nylon Hose	2
11	000-049-154	Deflector, Air - Univeral Recovery Tank	1
12	000-140-023	Rivet, AB8-6A Aluminum Pop	6
13	000-143-126	Screw, #10-24UNC x 0.50" Lg. Hex Head	5
14	000-143-051	Screw, #8-32UNC x 0.75" Lg. Binder Head Phillips	2
15	000-094-059	Nut, #8-32UNF Nylock	2
16	000-086-008	Latch, Bungie	1
17	000-143-539	Screw, #6-32UNC x 0.50" Lg. Button Head Allen	2
18	000-094-063	Nut, #6-32UNC Nylock	2
19	000-174-019	Washer, 1/4" Lock	2
20	000-174-003	Washer, 1/4" Flat	18
21	000-106-019	Plug, 1-1/2" NPT	1
22	000-052-763	Nipple, 1-1/2" IPS Close s/s	1
23	000-169-022	Valve, 1-1/2" Full Port Ball	1
24	000-052-226	Insert, 1-1/2" NPT x 1-1/2" Barb (Grey)	1
25	000-081-036	Label, Maintenace And Lubrication Schedule	1
26	000-143-333	Screw, 1/4"-20UNC x 0.50" Lg. Hex Head	2
27	000-174-029	Washer, 3/8" Rubber Back	2
28	000-174-036	Washer, #10 Flat Rubber Backed	5
29	000-143-002	Screw, 1/4"-20UNC x 1.00" Lg. Hex Head	12
30	000-094-009	Nut, 1/4"-20UNC Hex Nylock	8

100 Gallon Universal Recovery Tank Assembly Parts List

Item	Part Number	Description	Qty
31	000-166-002	Tray, Soap Jug - Weldment	1
32	000-094-034	Nut, #10-24UNC Nylock	2
33	000-057-206	Gasket, Adapter - Universal Recovery Tank	2
34	000-106-049	Plug, 1" NPT Allen Head	1
35	000-174-060	Washer, 1/4" Flat Rubber Backed	4
36	000-094-113	Nut, 1/4"-20UNC Neoprene Wellnut	4
37	000-001-135	Adapter, Tank To Ø3.0" x 90° Blower Hose - Universal Recov	1
38	000-106-007	Plug, 1/4" NPT Allen Head	1

Figure 5-12 100 Gallon Universal Recovery Tank Cover Assembly

D-6919 Rev -

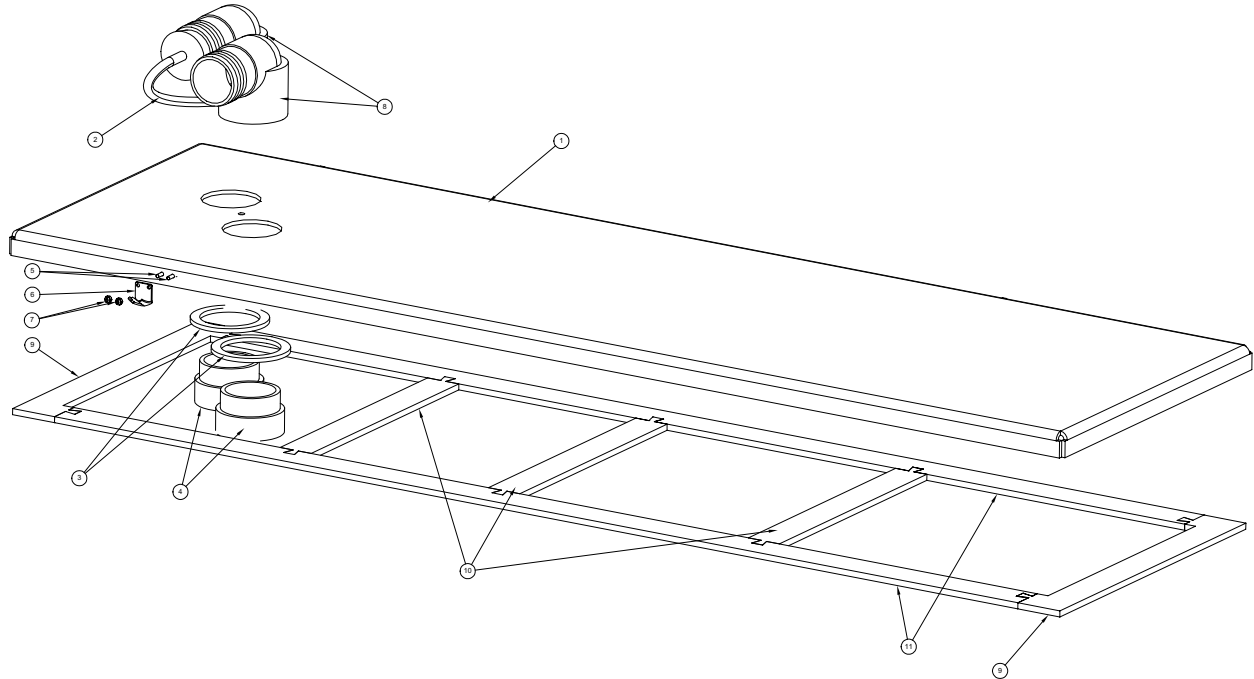

100 Gallon Universal Recovery Tank Cover Assembly Parts List

Item	Part Number	Description	Qty
1	000-041-447	Cover, 100 Gallon Universal Recovery Tank - Weldment	1
2	000-078-039	Vacuum Inlet Stopper Assembly - Recovery Tank	1
3	000-057-015	Gasket, 1-1/2" Bulkhead Fitting	2
4	000-052-219	Adapter, 2" NPT x 2" F Slip	2
5	000-143-539	Screw, #6-32UNC x 0.50" Lg. Button Head Allen	2
6	000-086-008	Latch, Bungie - Strike	1
7	000-094-063	Nut, #6-32UNC Nylock	2
8	000-052-222	Elbow, 2" Barb x 2" FPT	2
9	000-057-202	Gasket, End - Recovery Tank	2
10	000-057-203	Gasket, Middle - Recovery Tank	3
11	000-057-205	Gasket, Side - Recovery Tank - 100 Gallon	2

Figure 5-13 Vacuum Relief Valve Assembly

C-6894 Rev -

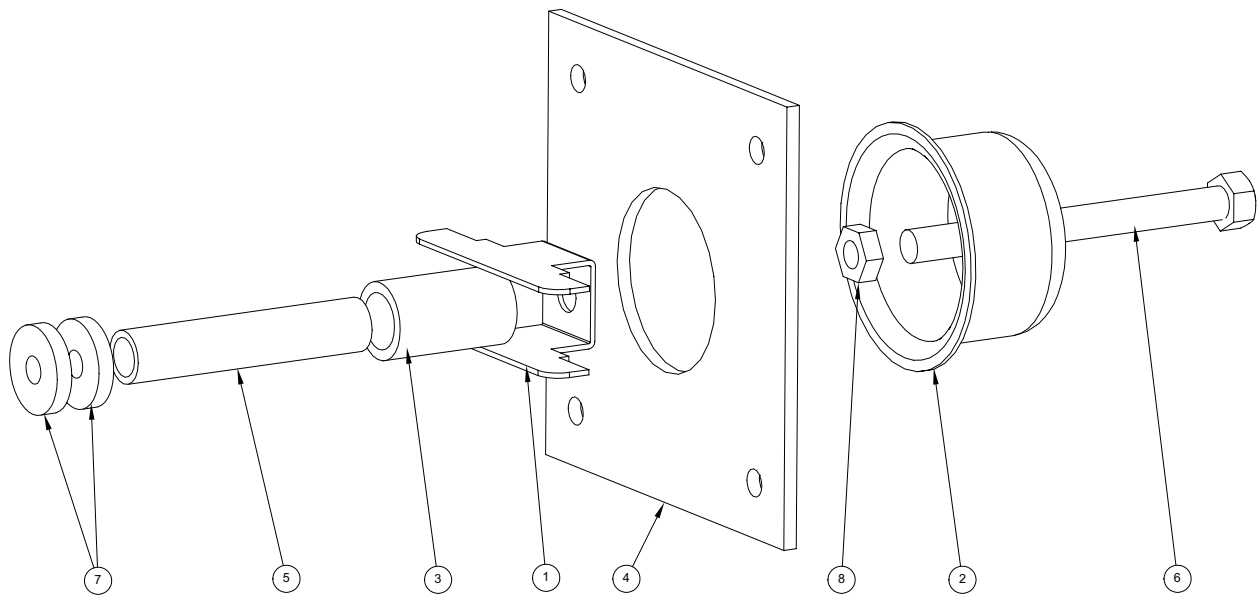

Vacuum Relief Valve Assembly Parts List

Item	Part Number	Description	Qty
1	000-015-182	Bracket, Vacuum Relief Valve	1
2	000-027-032	Cap, Vacuum Releif Valve	1
3	000-125-111	Pipe, Vacuum Relief Spring Guide	1
4	000-105-332	Plate, Vacuum Relief Valve Mounting - Universal Recovery T	1
5	000-155-026	Spring, Vacuum Relief	1
6	000-143-198	Screw, 3/8"-16UNC x 4" Lg. Hex Head Full Thread	1
7	000-094-077	Nut, 3/8"-16UNC x 1.00" O.D. Knurled	2
8	000-094-101	Nut, 3/8"-16UNC Hex Jam	1

Figure 5-14 **Dura-Flow APO Assembly**
D-5654 Rev E

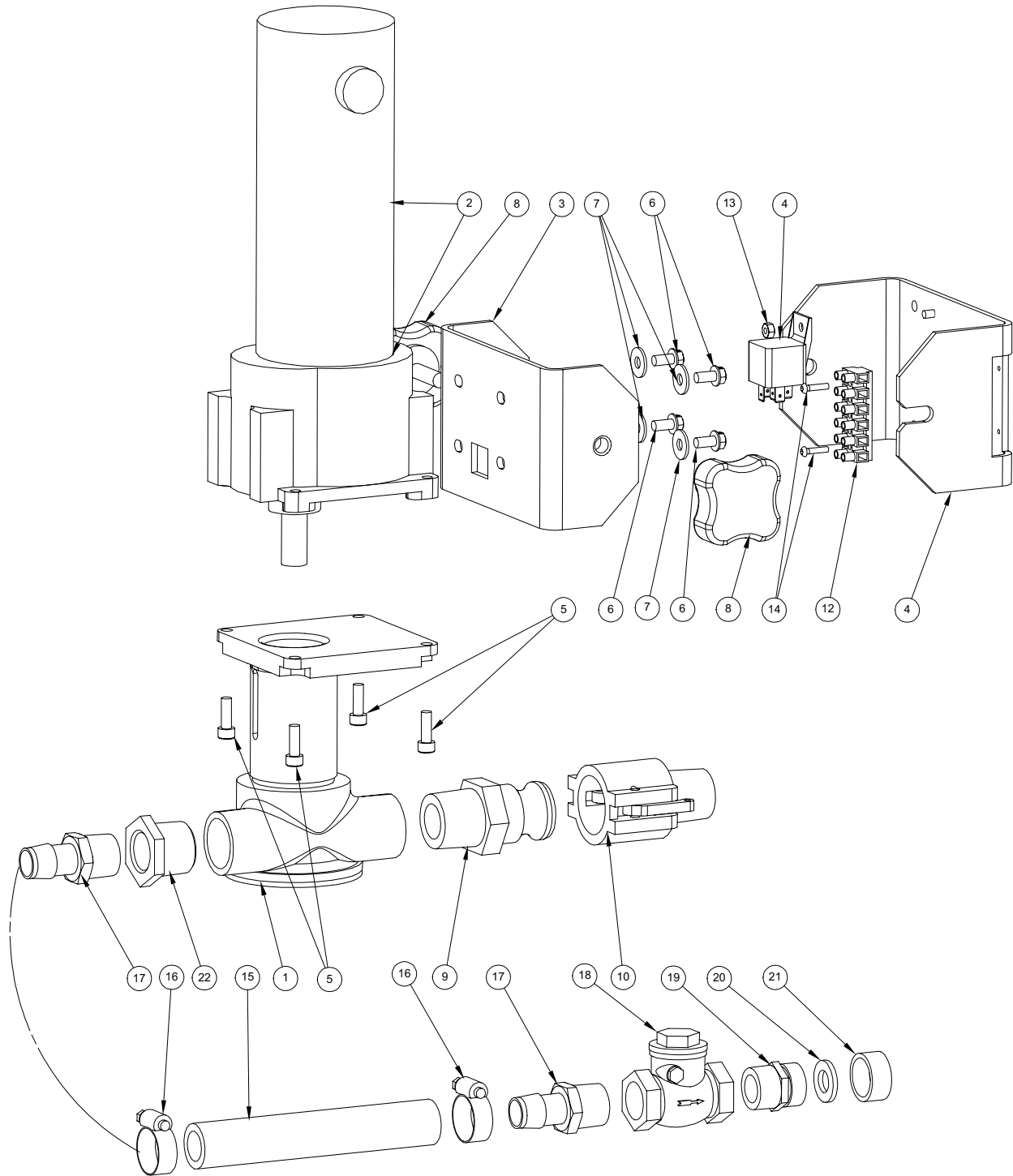

Dura-Flow APO Assembly Parts List

Item	Part Number	Description	Qty
1	000-111-169	Assembly, APO Pump - Jabsco	1
2	000-091-042	Motor, Bison 438 Series	1
3	000-015-891	Bracket, APO Clamp	1
4	000-015-890	Bracket, Tank Mounted APO Support	1
5	000-143-566	Screw, 1/4-28UNF x 0.75" Lg. Socket Head	4
6	000-143-074	Screw, 1/4"-20UNC x 0.50" Lg. Hex Head Self-Tapping	4
7	000-174-002	Washer, 1/4" Flat	4
8	000-061-131	Knob, Handle - Rdm	2
9	000-052-723	Fitting, 1" NPT Cam Lock - Banjo 100F	1
10	000-052-724	Fitting, 1" NPT Cam Lock - Banjo 100B	1
11	000-157-022	Switch, Relay	1
12	000-012-011	Block, 6 Post	1
13	000-094-027	Nut, #10-24UNC Hex	1
14	000-143-532	Screw, #6-32UNC x 5/8" Lg. Socket Head	2
15	000-068-069	Hose, 3/4" I.D. Weatherhead - Blue - Bulk.	1
16	000-033-026	Clamp, Size #10 Hose	2
17	000-052-338	Insert, #1212 (3/4" NPT x 3/4" Barb)	2
18	000-169-009	Valve, 3/4" FPT Swing Check	1
19	000-052-281	Nipple, 3/4" NPT x 3/4" Male Garden Hose	1
20	000-057-055	Gasket, Garden Hose	1
21	000-027-014	Cap, Garden Hose	1
22	000-052-425	Bushing, 1" NPT x 3/4" FPT	1

		<i>(To be Added)</i>		

Boxxer H₂O

		<i>(To be Added)</i>		

This page intentionally left blank

Vacuum System

The vacuum pump in this machine is commonly referred to as a 'positive displacement lobe' type blower. The performance and life of this unit is greatly dependent on the care and proper maintenance it receives.

Because of the close tolerances between the lobes and housing of the vacuum blower, solid objects entering the inlet will damage the internal lobes, gears, bearings or drive system.

To prevent this, a stainless steel filter screen has been placed at the vacuum inlet inside the vacuum recovery tank. This stainless steel screen is 'finger' tight and **should be removed for cleaning weekly.**

To protect the vacuum blower from overloading and damaging itself, there is a vacuum relief system installed on the vacuum tank. When the vacuum tank inlet is completely sealed off, a maximum of 12 HG will be attained.

At the end of each day, an oil based lubricant should be sprayed into the blower lubrication port before shutting down the machine. Lubricate the vacuum blower *daily* to prevent rust deposits and moisture that will decrease the life of the vacuum blower.

CAUTION

Foam passing through the blower could lead to serious problems.
It is important to keep the vacuum tank foam free.

Read the vacuum blower manual carefully for proper oil change. The maintenance log may differ slightly from the manual, but the truck-mounted carpet cleaning machine application is very demanding of the vacuum blower and therefore it should be maintained more regularly.

CAUTION

The vacuum tank is protected from overflowing by a vacuum tank float kill switch. The switch is not activated by foam, only by liquid.

VACUUM TANK FILTER BASKETS

HydraMaster filter baskets are designed to trap lint, sand and dirt that would normally collect at the bottom of your vacuum tank. The use of these filters, if emptied at the end of each job, will eliminate the build-up of much of the debris in the tank.

Vacuum System Troubleshooting

- 1.0. **Weak vacuum at wand. Gauge reads normal (10" to 12" with hoses & wand attached)**
 - 1.1. **Clogged hoses or wand tube.** Disconnect hoses and check carefully for an obstruction.
 - 1.2. **Excessive length of hoses connected to machine.** Make sure machine is rated for the conditions under which it is being operated.

- 2.0. **Vacuum gauge will not come up to 12" hg**
 - 2.1. **There is an air leak somewhere in the vacuum system.** Check vacuum relief valve for proper adjustment. Carefully check all vacuum hoses for a cut or break. Check recovery tank lid gasket. Make sure recovery tank drain valve is fully closed.
 - 2.2. **Vacuum blower is turning too slowly.** Check engine RPM. Adjust as necessary to 3000RPM.
 - 2.3. **The vacuum gauge is defective.** Test gauge and replace as necessary.

- 3.0. **Vacuum gauge reads too high with no hoses attached**
 - 3.1. **Filter in recovery tank is clogged.** Remove and clean or replace as necessary.
 - 3.2. **Hose from vacuum blower to recovery tank is collapsed internally.** Inspect and replace as necessary.

- 4.0. **Noisy vacuum blower**
 - 4.1. **Vacuum blower is low on oil.** Inspect oil level and replenish as necessary. Note: Running vacuum blower low on oil can cause severe mechanical damage. If this situation occurs, it should be inspected by a qualified service technician.
 - 4.2. **Vacuum blower has internal damage.** Refer to qualified service technician.

- 5.0. Vacuum blower is locked and will not turn.
 - 5.1. **The machine has been unused for a period on time and the blower was not properly lubricated when it was shut down, causing rust to build up on internal surfaces.** Spray penetrating oil into blower inlet and let sit for at least one hour. Then *very carefully* use pipe wrench on outer diameter of pulley on blower shaft and attempt to free up blower. *Do not use wrench directly on blower shaft.* If unable to free up blower in this manner, refer to qualified service technician.
 - 5.2. **There is internal damage to the blower.** Refer to qualified service technician.
-

Miscellaneous Troubleshooting

- 1.0. Water from exhaust
 - 1.1. **The recovery tank has been filled with foam or overfilled with water.** Remove recovery tank lid and inspect. If full, drain tank then inspect high-level shutoff switch for proper operation. Clean or replace switch as necessary.
 - 1.1.1. If foam is observed in recovery tank, use defoamer.
 - 1.2. **Condensation.** This will be more pronounced in cool weather and humid climates. Observe how long this condition persists after starting machine. If it is only until the machine *warms up, it is normal.*

This page intentionally left blank.

Electrical System

The Boxxer electrical system, in keeping with the entire machine concept, has been kept to a minimum so as to keep any necessary troubleshooting as easy as possible.

The entire electrical system operates on 12 volts DC which is provided by a battery. Battery levels are sustained by a 16 amp alternator inside the engine.

NOTE: When a new battery is installed, check that it is properly charged before installation or damage to the charging regulator may occur.

Boxxer H₂O

This page intentionally left blank

Figure 7-1 Wiring Schematic

D-6838 Rev -

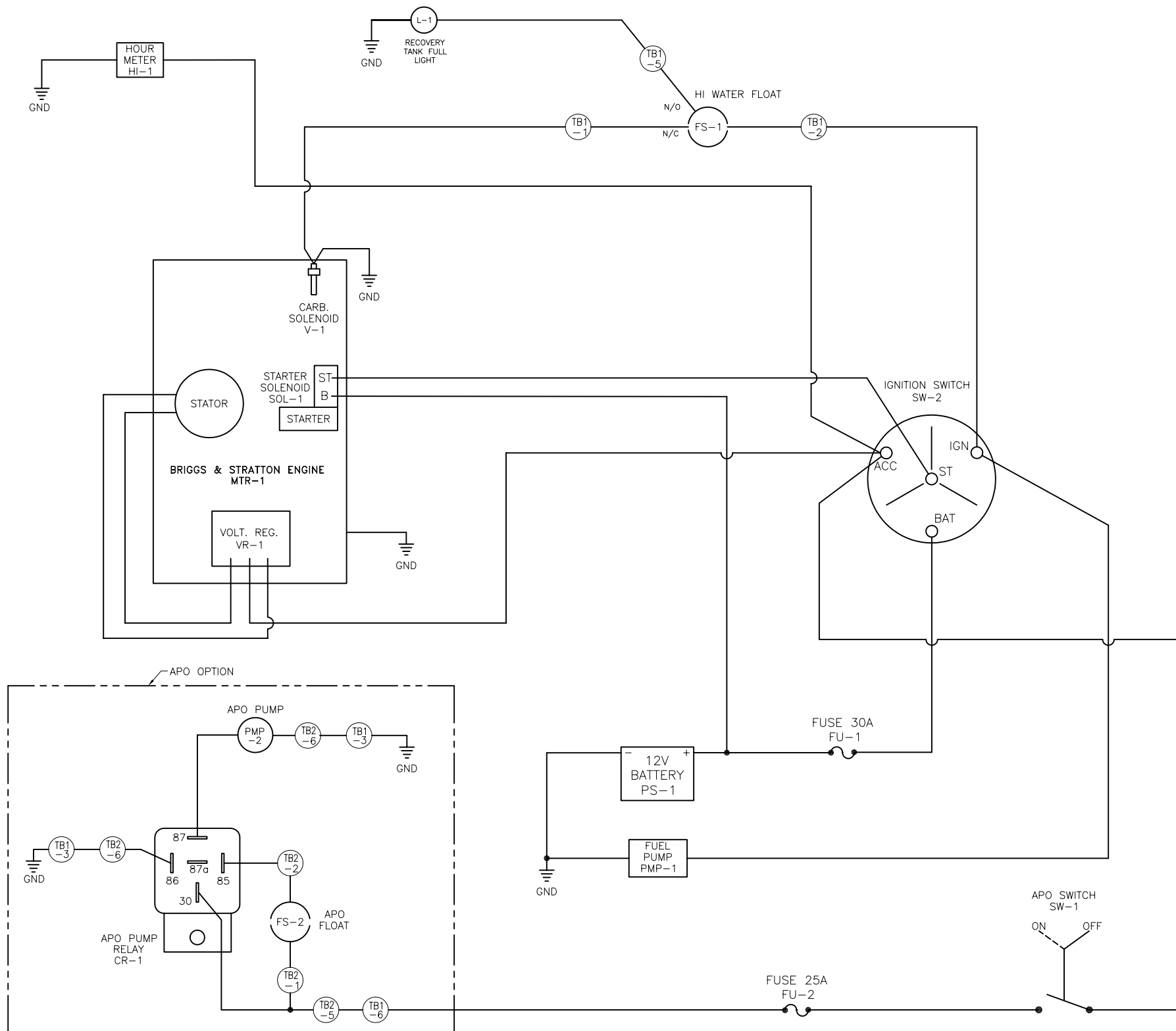

Boxxer H₂O

Figure 7-2 Wiring Diagram

D-6837 Rev -

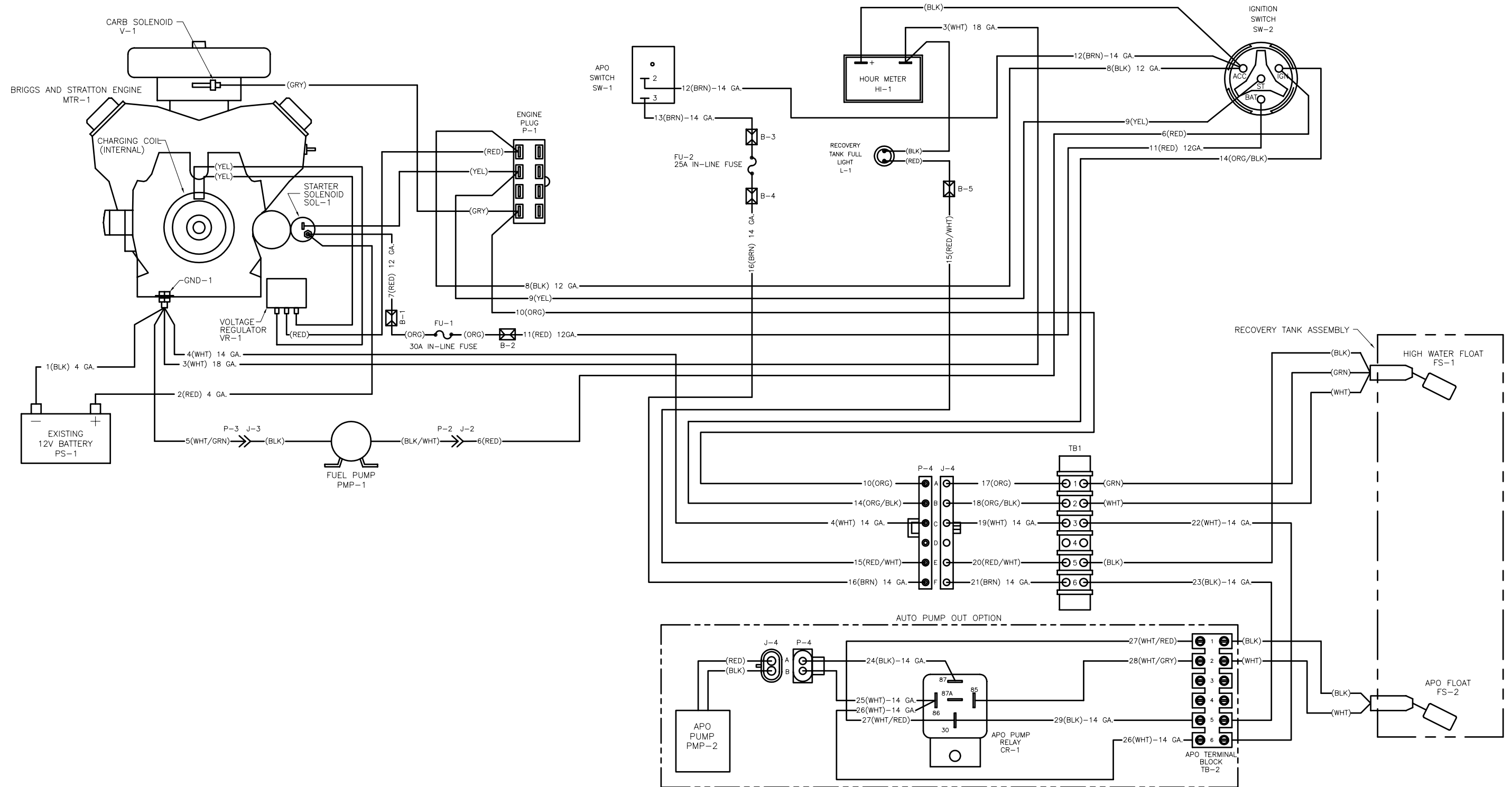

Electrical Troubleshooting

No.	Problem/Possible Cause	Solution
1.0	The engine is not charging the battery.	
1.1	The <i>regulator/rectifier</i> is bad.	Check the B+ voltage from the regulator/rectifier to ground. With the engine running at normal RPM the voltage should be 12.5 to 14.5 DC volts. If necessary, replace the regulator/rectifier.
1.2	The <i>stator winding</i> is bad.	Check for AC voltage at the regulator/rectifier. The stator should be producing an AC voltage of around 25 to 40 volts. Check your Owner's manual for the exact voltage. If necessary, replace the stator winding.

No.	Problem/Possible Cause	Solution
2.0	The fuse is blown.	
2.1	There is an <i>electrical short</i> in the system.	Check for a loose wire or a wire that has rubbed its insulation off and is shorting out to ground. Unscrew each individual wire (except the white wires) one at a time until the fuse does not trip. Then trace that circuit.

Boxxer H₂O

This page intentionally left blank.

Engine Troubleshooting

1.0. Will not turn over

- 1.1. **There is a loose or corroded battery terminal.** Clean and tighten the battery terminal connections.
- 1.2. **The battery is dead.** Recharge or replace the battery. Test the charging system. Repair if necessary.

CAUTION

Do not attempt to jump-start this machine from a running vehicle. The amperage output from an automobile will damage the charging system of the truckmount.

- 1.3. **The 25 amp main power fuse in the electrical panel has blown.** Inspect the wiring thoroughly to locate shorted or damaged wires.
- 1.4. **The vacuum blower has seized.** Attempt to turn the engine by hand. If it will not turn, refer to Vacuum System section.
- 1.5. **The ignition switch is defective.** Test to see if there is 12 volts to the switch. If there is, but there is not 12 volts going from the switch, replace the switch.
- 1.6. **There is a problem with the starter solenoid.** If there is 12 volts at the battery connection and at the key switch connection with the key in the start position but there is not 12 volts on the starter connection of the solenoid, replace the solenoid.
- 1.7. **The starter motor is defective.** Check to see if the engine can be turned over by hand. If it can and if there is 12 volts from the starter solenoid to the starter, replace the starter.
- 1.8. **There is a mechanical problem with the engine.** If the engine can be turned over by hand and the vacuum blower is not locked, refer the engine to a qualified service technician to determine the cause of the problem.

2.0. Turns over but will not start. There *is no* spark

Note: To check for spark, use the following procedure. Remove a spark plug from the engine. Attach the lead wire back onto the plug. Ground the threaded part of the spark plug to an unpainted engine surface. While holding the plug and wire assembly by the insulated wire, crank the engine over by turning the ignition switch to the "start" position. You should observe a blue spark between the two electrodes of the spark plug.)

- 2.1. **The spark plugs are faulty.** Remove and inspect. Replace as necessary.
 - 2.2. **The engine ignition system is malfunctioning.** Refer to a qualified engine service technician for inspection.
-

3.0. Turns over but will not start. There *is* spark.

- 3.1. **Fuel is not reaching the carburetor inlet.** Check the fuel pump. If the pump is working, inspect the fuel lines between the fuel source and the carburetor. Repair or replace any faulty parts as necessary.
 - 3.1.1. If the pump *is not* working, check for 12 volts and a ground at the pump.
 - 3.1.2. If 12 volts *is not* present at the pump, check the wiring to the pump, including the fuse. Repair or replace as necessary. Note: If the fuse has blown, carefully inspect the wiring for a shorted or damaged wire. Repair immediately.
 - 3.1.3. If 12 volts *is* present at the pump and the ground is good, replace the pump.
- 3.2. **Recovery tank is full.** Empty the tank.
- 3.3. **Recovery tank float is defective.** Disconnect float. If engine starts, replace the float.
- 3.4. **The carb solenoid is malfunctioning.** Test for 12 volts and proper ground at solenoid. If both test okay, replace the solenoid.
- 3.5. **The engine is flooded.** Wait for a few minutes and attempt to start with the choke open. **Note:** If the engine has been flooded, it may be necessary to remove and clean the spark plugs.
- 3.6. **The spark plugs are dirty or worn.** Inspect and replace as necessary.
- 3.7. **There is a mechanical problem with the engine.** Have engine inspected by a qualified engine service technician.

4.0. Will not come up to normal operating RPM

- 4.1. **Throttle linkage is out of adjustment.** Inspect for broken or loose linkage. Repair or replace as necessary and adjust to proper RPM. Note: It is important to use an accurate tachometer to adjust engine speed to 3000 RPM while it is under a vacuum load of between 10"hg and 14"hg. Too high or too low will cause severe damage to machine components.
 - 4.2. **There is excessive load on the engine due to the blower-to-recovery tank hose becoming delaminated.** Remove and inspect the inside of the hose. Replace as necessary.
 - 4.3. **There is excessive back-pressure on the engine or blower exhaust.** Check for clogged blower heat exchanger.
-

5.0. Runs rough at medium or high speed

- 5.1. **One or both spark plugs are defective.** Remove and inspect spark plugs. Replace as necessary.
- 5.2. **A spark plug wire is loose at the spark plug or has been damaged.** Inspect wire. Replace wire and coil as necessary.
- 5.3. **Low compression on one or both cylinders.** Check compression. If low, check valve adjustment. If incorrect, adjust to proper specs. This operation should be performed by a qualified service technician.
 - 5.3.1. If adjustment is okay, there is a possibility of burned valves, burned head gasket or worn cylinders. Refer to qualified engine service technician.
- 5.4. **Poor spark on one or both cylinders.** Refer to qualified engine service technician.
- 5.5. **Inadequate fuel supply to the carburetor.** Test the fuel volume at the carburetor by removing the fuel line from the carburetor inlet and placing the line in a metal container with a minimum of 16 oz. capacity. Turn on the ignition switch to operate the fuel pump. The fuel flow volume should be 12 oz. / minute. Check for clogged filter or obstructed fuel line. Also check to make sure the fuel pump is mounted vertically and is close to the fuel source. Repair as necessary.

6.0.Runs rich (Black smoke)

- 6.1. **Dirty air filter.** Inspect and replace as necessary.
 - 6.2. **Choke is partially closed.** Inspect and adjust or repair as necessary.
 - 6.3. **Excessive fuel to carburetor.** Insure that fuel pump is proper PSI rating. A fuel pump with a psi rating in excess of that of the pump supplied with the machine could overpower the inlet valve in the carburetor, causing excessive fuel to be supplied to the carburetor.
-

7.0.Engine overheats

- 7.1. **Poor ventilation in vehicle.** All cargo area doors must be open for proper ventilation. Roof vents are strongly recommended for machines that are operated in hot climates. Any item that might restrict air flow to the machine such as other equipment or a solid divider should be moved or modified to permit proper air flow.
- 7.2. **Low engine oil level.** Check oil level and replenish as necessary.
- 7.3. **Engine RPM too high.** Check RPM with an accurate tachometer. Adjust as necessary to 3000 RPM.
- 7.4. **Restricted engine or blower exhaust.** Disassemble exhaust components to locate restriction. Repair as necessary.

How to Order Parts

To obtain a proper diagnosis of your malfunction, and to order warranty replacement parts or repairs, it is important that you proceed in the following manner:

WARRANTY PARTS ORDERS

1. Call the local distributor where you purchased your equipment and ask for the Service Department.
2. Have the following information ready:
 - A. Equipment Model
 - B. Date of Purchase
 - C. Hours on the Unit
 - D. Unit Serial Number
 - E. Description of Malfunction
3. Once it has been determined which parts are needed to correct the problem with your machine, make arrangements with your distributor to either perform the repairs or ship the parts to you.

PARTS ORDERS

Call your local distributor. In most instances, they either stock or have access to parts through a regional service center.

EMERGENCIES

If, for any reason, your distributor is unable to supply you with the necessary parts, they may call us and arrange for expedited shipping.

HydraMaster sells parts only through authorized distributors and service centers.

ONE FINAL NOTE

Any questions you have regarding the warranty program should be directed to the:

HydraMaster Customer Service Department
(425) 775-7275,
8 a.m. to 5 p.m.
Monday through Friday (PST).

We shall always endeavor to be fair in our evaluation of your warranty claim, and shall provide you with a complete analysis of our findings.

HydraMaster warranty covers only defective materials and/or workmanship for the periods listed. **Labor and/or diagnostic reimbursement is specifically excluded.**

Warranty Information

To avoid misunderstandings which might occur between machine owners and manufacturer, we are listing causes of component failure that specifically voids warranty coverage. Such causes as listed below shall constitute **abuse** or **neglect**.

BLOWER:

- Failure to lubricate impellers daily with an oil based lubricant.
- Failure to lubricate bearings as recommended in blower manual.
- Failure to maintain proper oil levels in the blower.
- Failure to use the correct oil grade and viscosity as recommended in blower manual.
- Failure to properly maintain blower safeguard systems such as waste tank filter screen, vacuum safety relief valve and waste tank automatic shut-off system.
- Allowing foam to pass through blower.

VACUUM TANK:

- Failure to properly maintain filtering devices in tank.
- Failure to clean tank as recommended by manufacturer.
- Failure to maintain vacuum safety release in tank.

VACUUM HOSES:

- Failure to protect hoses against burns from engine and blower exhaust.
- Damage to hoses from being run over by vehicles.
- Kinking or cracking from failure to store or unroll hoses correctly.
- Normal wear and tear from everyday use.

RECOVERY WAND:

- Obvious physical abuse of wand.

Boxxer H₂O

WARRANTY PROCEDURE

Warranty coverage is available to you through *your local Distributor*.

If you have moved to a new area or have purchased a used machine and need information regarding your local distributor, call HydraMaster at (425) 775-7272 or email us at custsvc@hydramaster.com.

When calling your distributor, be sure to have the machine's information; model and serial number, ready for the service representative.

IMPORTANT: HydraMaster's warranty policy provides replacement parts without charge for thirty (30) days to distributors maintaining current account status. An invoice will be sent to the distributor for the amount of the parts sent. The customer's faulty parts **must be** returned for evaluation prior to the expiration of the thirty (30) day period. Upon warranty approval, a credit will be issued the distributor for the replacement parts invoice. **Warranty disapproval or failure to return the faulty parts within the thirty (30) day period allowed will result in the customer being charged for the replacement parts sent.**

FOR YOUR REFERENCE:

Model No. _____
Serial No. _____
Date of Purchase: _____
Purchased From (Distributor): _____